

# Design Manual

## for Small Scale Irrigation Scheme



**Ministry of Federal Affairs and Local Development**  
**Department of Local Infrastructure Development and Agricultural Roads**  
**(DoLIDAR)**

2071 (2014)

This "Design Manual for Small Scale Irrigation Scheme" is approved by the Government of Nepal (Ministry level) on 2071-03-23

Published by:

Ministry of Federal Affairs and Local Development  
Department of Local Infrastructure Development and Agricultural Roads (DoLIDAR)

In association with:

Swiss Agency for Development and Cooperation SDC Nepal  
Local Infrastructure for Livelihood Improvement (LILI), HELVETAS Swiss Intercooperation Nepal

Technical Team:

Mr. Kumar Thapa, Senior Divisional Engineer/ DoLIDAR  
Mr. Raju Shrestha, Engineer/ DoLIDAR  
Mr. Susan Shakya, Technical Coordinator/ LILI- HELVETAS Swiss Intercooperation Nepal

This Publication is available at:

Ministry of Federal Affairs and Local Development  
Department of Local Infrastructure Development and Agricultural Roads (DoLIDAR)  
Shree Mahal Pulchowk Lalitpur, Nepal  
Contact Phone: 977-1-5555001, 5555362, 5543197  
Fax: 977-1-5555724  
Email: [contact@dolidar.gov.np](mailto:contact@dolidar.gov.np) ; [dg@dolidar.gov.np](mailto:dg@dolidar.gov.np)



**Government of Nepal**  
**Ministry of Federal Affairs and Local Development**  
**Department of Local Infrastructure Development and Agricultural Roads**  
**(DoLIDAR)**

**Shree Mahal, Pulchowk, Lalitpur**

## Foreword

Government of Nepal has enacted Local Infrastructure Development Policy (LIDP) 2061 in order to accelerate the pace of rural development and to reduce the rural poverty by improving the access of rural people to goods, service and facilities for the betterment of their life. The policy states that Department of Local Infrastructure and Agricultural Roads (DoLIDAR) under Ministry of Federal Affairs and Local Development (MoFALD) has mandate for implementation of small irrigation projects, whereas it has number of other infrastructure sectors with the responsibility of coordination and facilitation to expedite the process of decentralization.

Small Scale Irrigation projects is now a day implementing by different agencies. Nevertheless, local bodies with the technical assistance of District Technical office (DTOs) are also implementing few small irrigation projects every year either solely by themselves or in association with different line/donor agencies, GOs, INGOs etc. In addition DoLIDAR and District Technical Office (DTOs) as its implementing unit at local level have been implementing small irrigation projects with conditional grant through MoFALD/DoLIDAR. DoLIDAR in collaboration with HELVETAS Swiss Intercooperation Nepal is also implementing Local Infrastructure for Livelihood Improvement (LILI) project funded by Swiss Agency for Development Cooperation. Similarly, Department has started to implement Community Irrigation Project funded by Asian Development Bank. Both the projects are focused on small irrigation development.

Considering the importance of harmonized implementation approach and to bring uniformity and technical betterment to implement small irrigation projects at the community level, this Design Manual has been developed on the basis of experiences so far DoLIDAR aiming to facilitate in survey, design and construction of small scale irrigation system in Nepal.

Finally, I would like to express my sincere gratitude to Swiss Agency for Development and Cooperation Nepal (SDC), HELVETAS Swiss Intercooperation Nepal and Technical Committee Members for their support and effort to develop this manual. We will welcome any constructive suggestions for its further improvement.



Jeewan Kumar Shrestha

Director General

DoLIDAR

**Director Général**

## TABLE OF CONTENTS

ABBREVIATIONS .....	1
1. Introduction .....	2
1.1 Concept of Irrigation .....	2
1.1.1 Surface Irrigation .....	2
1.1.2 Sub-surface Irrigation .....	2
1.1.3 Sprinkle Irrigation .....	2
1.1.4 Sources of Irrigation .....	3
1.2 Basic Terms Used In Small Scale Irrigation .....	3
1.3 Scope of the Manual .....	4
2. Project Study and Survey .....	5
2.1 Introduction.....	5
2.2 Identification Study .....	5
2.2.1 Introduction.....	5
2.2.2 Desk study .....	6
2.2.3 Field visit.....	6
2.2.4 Analysis and Reporting .....	6
2.3 Feasibility study .....	7
2.3.1 Introduction.....	7
2.3.2 Desk study .....	7
2.3.3 Field Survey Work.....	7
2.3.4 Field data analysis .....	8
2.4 Topographical Survey .....	9
2.5 Hydrological survey .....	10
2.6 Socio-economic Survey.....	10
2.7 Agricultural Survey .....	10
3. Hydrological Analysis and Water Requirement Assessment.....	12
3.1 Maximum Design discharge .....	12
3.2 Flood Frequency Analysis .....	12
3.3 Regional Analysis .....	12
3.3.1 Sharma and Adhikari Method .....	13
3.3.2 Rational Method.....	13
3.4 Water Availability for Irrigation.....	13
3.4.1 General .....	13

3.4.2	Frequency Analysis .....	14
3.4.3	MIP Method.....	14
3.5	Discharge Measurement .....	14
3.5.1	General .....	14
3.5.2	Float method .....	15
3.5.3	Bucket and Watch method.....	16
3.5.4	Current Meter.....	16
3.6	Water Requirement Assessment.....	16
3.6.1	Crop Water Requirements .....	16
3.6.2	Irrigation Water Duty .....	17
4.	Diversion Headworks and Intakes .....	18
4.1	Selection of Site for Headwork or Intake .....	18
4.2	Types of Intake .....	19
4.3	Design of Simple Side Intake .....	19
4.4	Bottom Intake.....	20
4.4.1	General .....	20
4.5	Diversion Weir .....	21
4.5.1	General .....	21
4.5.2	Crest Level of Weir and Under-sluice.....	21
4.5.3	Length of Weir and Afflux.....	22
4.5.4	Effect of Retrogression .....	22
4.5.5	Hydraulic Jump .....	23
4.6	Gabion Weir.....	24
4.6.1	Gabion weir .....	24
5.	Canal Design.....	26
5.1	Design Concept.....	26
5.2	Design of Unlined Canals.....	26
5.2.1	Design Procedure .....	26
5.2.2	Side Slopes.....	27
5.2.3	Permissible Velocity .....	27
5.2.4	Bed Width to Depth Ratio .....	28
5.2.5	Canal Slope .....	28
5.2.6	Free Board .....	29
5.2.7	Minimum Radius of Curvature .....	29

5.2.8	Design Example of Unlined Canal.....	29
5.3	Lining of Canals.....	30
5.3.1	Type of Canal Lining.....	30
5.3.2	Design Concept of Lined Canal.....	30
5.3.3	Design Procedure of Lined Canal.....	31
5.3.4	Design Example of Lined Canal.....	31
5.4	Design of Covered Canals.....	32
5.4.1	Design Concept.....	32
5.4.2	Design of Piped Canal.....	32
5.4.3	Design Examples of Piped Canal.....	33
6.	Sediment Control Structures.....	36
6.1	Gravel Traps.....	36
6.2	Sand Traps.....	37
6.2.1	General Configuration.....	37
6.2.2	Sand Trap Design.....	38
7.	Canal Structures.....	41
7.1	Head Regulator.....	41
7.2	Cross Regulator.....	41
7.3	Proportional Divider.....	41
7.4	Outlets.....	42
7.4.1	Design of Pipe Outlet.....	42
7.5	Drop Structures.....	42
7.6	Escape Structure.....	43
7.7	Bridges and Culverts.....	44
7.8	Retaining Wall.....	45
7.8.1	General.....	45
7.8.2	Design Concept of Dry and Gabion Retaining Wall.....	45
7.8.3	Design Procedure of Masonry and Concrete Retaining Wall.....	45
8.	Cross Drainage Structures.....	48
8.1	Type of Cross-Drainage Structure.....	48
8.2	Design Considerations.....	48
8.2.1	Design Discharge.....	48
8.2.2	Waterway of the Drain.....	48
8.2.3	Contraction and Expansion of Waterway.....	48

8.2.4	Head Loss through Structure.....	48
8.3	Design Concept of Aqueduct.....	49
8.4	Design Concept of Superpassage.....	50
8.5	Design Concept of Canal Siphon.....	50
8.6	Design Concept of HDP Pipe Crossing.....	51
8.7	Design Example of HDP Pipe Crossing.....	53
9.	Shallow Tube Well Irrigation.....	54
9.1	Groundwater Potential in Nepal.....	54
9.2	Design concept.....	55
9.3	Suggested Design Criteria.....	56
9.4	Design Procedure of STW.....	56
9.5	STW Design Example.....	57
9.5.1	Design Data.....	57
9.5.2	Assumptions Made.....	57
9.5.3	STW Planning.....	57
9.5.4	Tube-well Design.....	57
9.5.5	Pump and Motor Design.....	58
9.5.6	Distribution System.....	58
10.	Micro Irrigation.....	59
10.1	Introduction.....	59
10.2	Pond Irrigation.....	59
10.2.1	Design Concept.....	59
10.2.2	Design Example of Pond Irrigation.....	60
10.3	Sprinkle Irrigation.....	60
10.3.1	Sprinkle System Components.....	60
10.3.2	Micro Sprinkle in Nepal.....	61
10.4	Drip Irrigation.....	62
10.4.1	Components of Drip System.....	62
10.4.2	Simple Drip System in Nepal.....	63
10.5	Small Scale Lift Irrigation.....	64
10.5.1	General.....	64
10.5.2	Diesel or petrol engine pumps.....	65
10.5.3	Hydraulic Ram.....	66
10.5.4	Treadle Pump.....	67

11. Agriculture Benefit Assessment .....	68
11.1 Introduction.....	68
11.2 Benefit Matrix Approach .....	68
11.3 Components of Benefit Matrix.....	68
11.3.1 Command Area.....	68
11.3.2 Crop Yields .....	68
11.3.3 Agriculture Inputs .....	68
11.3.4 Economic Prices.....	69
11.4 Procedure of Benefit Assessment .....	69
11.4.1 Total Net Agricultural Returns “Without Project” .....	69
11.4.2 Total Net Agricultural Returns “With Project” .....	69
12. Project Cost Estimate .....	72
12.1 Introduction.....	72
12.2 Derivation of Unit Rates .....	72
12.3 Bill of Quantities and Abstract of Costs .....	74
13. Economic Analysis .....	75
13.1 Introduction.....	75
13.2 Economic Indicators .....	75
13.3 Basic Assumptions .....	75
Annex: 1 .....	77
Annex: 2 .....	82
Annex: 3 .....	88
Annex: 4 .....	94
Annex: 5 .....	95
Typical Drawings Sample .....	96



## ABBREVIATIONS

ADB	:	Asian Development Bank
CA	:	Catchment Area
CCA	:	Cultural Command Area
CWR	:	Crop Water Requirement
DDC	:	District Development Committee
DHM	:	Department of Hydrology and Meteorology
DOI	:	Department of Irrigation
DOLIDAR	:	Department of Local Infrastructure Development and Agricultural Roads
DTO	:	District Technical Office
EIRR	:	Economic Internal Rate of Return
FAO	:	Food and Agriculture Organization
FM	:	Frequency Modulus
FMIS	:	Farmer Managed Irrigation System
GCA	:	Gross Command Area
GPS	:	Global Positioning System
HDP	:	High Density Polythene
LILI	:	Local Infrastructure for Livelihood Improvement
MOA	:	Ministry of Agriculture
MOFALD	:	Ministry of Federal Affairs and Local Development
NCWR	:	Net Crop Water Requirement
O&M	:	Operation and Maintenance
PDSP	:	Planning and Design Strengthening Project
SDC	:	Swiss Development Cooperation
STW	:	Shallow Tube Well
VDC	:	Village Development Committee
WB	:	World Bank
WECS	:	Water and Energy Commission Secretariat
WUA	:	Water Users Association

### 1. Introduction

#### 1.1 Concept of Irrigation

Irrigation is the application of water to the farm land for the purpose of producing crops whenever and wherever the rainfall is not sufficient to meet the requirements of the crops. Irrigation system can be classified according to size, source of water, technology, management type etc. In-terms of management there are three broad types of irrigation systems are practiced in Nepal i.e. government managed, farmer managed, and jointly managed system. However basically almost all small scale irrigation schemes are under farmer managed system.

There are basically three types of water application technologies for irrigation:

- Application of water at the surface of the field-Surface irrigation;
- Application of water below the surface of the field-Sub-surface irrigation and
- Application of water from above the field or in the form of rain- Sprinkle irrigation

##### 1.1.1 Surface Irrigation

In this system water is applied at the surface of the fields. This is the oldest and most commonly practiced system of irrigation. Surface irrigation methods are categorized in the main groups:

- Free flooding irrigation,
- Boarder strip flooding irrigation, and
- Furrow irrigation

In free flooding field plots are divided into small plots nearly leveled and water is applied at higher level to allow free flooding. Irrigation of paddy fields is the example of free flooding irrigation.

In boarder strip flooding the land is divided into number of strips. The size of strip depends upon the technology used for mechanization. Shorter and narrower strips are more efficient. Irrigation of wheat fields and mechanized paddy fields are the examples of this irrigation method.

In furrow irrigation furrows are constructed at certain intervals and crops are planted in rows. The length and width of furrow depends upon the field condition and the technology used. Irrigation of potato and vegetables are the examples of furrow irrigation.

##### 1.1.2 Sub-surface Irrigation

In this type of irrigation water is applied at the roots of the plants. This method is economical in water utilization as evaporation losses are minimal. But it has limited application due to technological constraints and economic point of view. This type of irrigation is suitable for water scarce area and for growing cash crops. Drip or trickle irrigation is being practiced in Nepal for growing vegetable crops in small holder farmers.

##### 1.1.3 Sprinkle Irrigation

In this type of irrigation water is applied from above the surface of the field in the form of rain or spray. It is mechanical form of irrigation and needs pressure flow for spraying water. It is widely used in developed countries for watering of gardens and lawns. In Nepal sprinkle irrigation has been practicing in tea gardens since long. It is also being used for growing vegetable crops in water scarce area and in areas of porous soil.

### 1.1.4 Sources of Irrigation

The main sources of water supply for irrigation are:

- Normal flow of rivers, lakes, spring sources;
- Stored flood water in reservoirs or rainfall stored in tanks; and
- Wells including tube wells

Irrigation water is generally diverted from source to the field by means of a conveyance system. The design of small scale irrigation covers water acquisition structure, conveyance system, storage system, and application method.

## 1.2 Basic Terms Used In Small Scale Irrigation

Afflux	:	the rise of water level on the u/s of the weir or barrage after its construction,
Alignment	:	center line of the canal to be followed for excavation or profiling,
Apron	:	floor to protect the surface from erosion,
Aqueduct	:	cross drainage structure made over drainage to pass the canal water,
Barrage	:	structure across the river with gates to raise the water level for irrigation canals,
Bench mark	:	geodetic reference point taken from national survey of the country,
Breast wall	:	vertical wall immediately above the face of orifice or gate,
Catchment area:		area from which rainfall flows into a drainage line,
Chute	:	high velocity conduit for conveying water,
Command area :		area which can be irrigated or cultivated,
Cultural command area (CCA):		total area which can be cultivated,
Gross command area (GCA):		total area which can be economically irrigated by irrigation system,
Cropping intensity:		percentage of irrigated area cropped within the command area in a year,
Cropping pattern:		crop planting sequence and crop mix throughout a year,
Cross drainage works:		structure necessary to cross the irrigation canal across the natural drainage,
Cut-off	:	wall constructed below the floor of the structure to reduce percolation,
Desilting basin	:	structure for creating pool of water to settle down suspended sediments,
Drop	:	structure for dropping the flow of the canal to dissipate its surplus energy,
Embankment	:	earthwork raised above the natural ground to protect flood water,
Free board	:	margin between a canal bank and full supply level,
Guide bank	:	training bank constructed at the site of bridge or barrage to guide the river,
Head regulator :		control structure constructed at the head of the off-take canal,
Headwork	:	combination of structures constructed at the diversion point of the river,
Hydrograph	:	graph showing the stage, flow of water with respect to time,
Intake	:	structure to divert water from the source to the canal system,
Lining	:	method of sealing the section of canal to prevent seepage,
Main canal	:	canal that takes off water from the headwork or from the intake,
Marginal bund :		embankment constructed along the river at a short distance from the margin,
Off-take	:	structure to take off the water from parent canal to a relatively small canal,
Percolation	:	flow of water in sub-soil due to the force of gravity or pressure head,
Pier	:	intermediate support of the bridge or culvert,
Pitching	:	covering of the sloping surface with stone, concrete blocks, bricks, etc,
Regime	:	state of the river flowing in non-scouring and no-silting condition,
Retaining wall :		vertical wall to retain the soil mass behind it,
Runoff	:	part of rainfall that reaches the stream, drain from the catchment,

Scour	:	removal of material from the bed of the channel by flowing water,
Sediment	:	non-floating material transported by water (sand, silt, gravel and clay),
Seepage	:	percolation of water into the soil underneath the structure,
Side slope	:	sloping distance of a canal section usually measured in a ratio,
Silt	:	water-borne sediment consisting of fine earth, sand or mud,
Siphon	:	closed inverted conduit for cross-drainage structure,
Sluice	:	conduit for carrying water at high velocity,
Spillway	:	passage for the flow of surplus water in a weir or conduit,
Stilling basin	:	structure for creating pool of water to disseminate the surplus energy of water,
Super-passage	:	structure over the canal to bypass the drainage flow,
Tail-water	:	water just downstream of the structure,
Uplift	:	upward pressure of water on the base of structure,
Waterway	:	distance required for flowing water, e.g. Lacey's waterway,
Weep-holes	:	horizontal holes on the walls to allow flow of seepage water behind it,
Weir	:	barrier built across the river to raise the water level upstream,
Wing wall	:	splayed extension of an abutment wall of the culvert,

### 1.3 Scope of the Manual

Several reference books and manuals are available for planning and design of irrigation schemes. Most of these references focus on large and medium irrigation schemes. The design of small irrigation schemes is specific with respect to its size and nature. Based on the experience of planning, designing and implementing small scale irrigation schemes by various organizations, it is high time to focus on the design of small scale irrigation. In this aspect this manual tries to address the following scope of work:

- Review available design manuals and design guidelines and identify various types of possible components/structures, which are normally required for small irrigation schemes;
- Prepare of stepwise procedures for the design of small irrigation canals and associated structures;
- Prepare acceptable standard design manual of small scale irrigation schemes with necessary drawings.

## **2. Project Study and Survey**

### **2.1 Introduction**

Study and survey is the basic requirement of any engineering project. The success and failure of the project implementation depends on the accuracy its study and survey. In irrigation projects the major studies carried out for project implementation are:

- Identification study,
- Pre-feasibility study,
- Feasibility study, and
- Detailed study

For small scale irrigation schemes it may be sufficient to carry out two levels of the study:

- Identification study, and
- Detail Feasibility study

Survey work is an integral part of the scheme study and is carried out in all stages of the study. The magnitude and accuracy of the survey work depends on the stage of the study and its accuracy to be needed. The principal types of survey required for small scale irrigation schemes are:

- Topographical survey,
- Engineering survey,
- Hydrological survey,
- Socio-economic survey,
- Agricultural survey

This chapter deals with the requirements of the study and survey for the implementation of small scale irrigation schemes.

## **2.2 Identification Study**

### **2.2.1 Introduction**

The identification of the scheme is the very first step of project implementation process. The district level offices (District Technical Office) should disseminate the information about the project, its plans, procedures and requirements for implementation of the project through meetings with VDCs, DDCs, and local FM to the farmers of the district.

Prior to start of identification study, the request from the farmers should be reviewed to establish whether they fulfill the minimum set requirements. The criteria for selection of scheme for identification should be prepared by DTO based on its principles and objectives. The criteria for the selection of the project for identification may be:

- At least two-third of the beneficiary households should sign the project request form;
- There are no potential water right disputes;
- The beneficiaries commit to take future O&M responsibilities;
- Sufficient water is available;

After the very first initial screening identification study of the project need to be processed. Engineering and socio-agricultural staff should visit the proposed project site and assess whether the project should be carried on the feasibility study or rejected. The project identification study is carried out in three steps:

- Desk study

- Field visit (Walkthrough survey)
- Analysis and reporting

### **2.2.2 Desk study**

At this step the project location should be identified on the topographic maps (1:50,000/1:25,000 scale). The team should collect and review the demand form/previous reports/study/information related to the project.

### **2.2.3 Field visit**

After desk study, message should be sent to the farmers before the field visit informing them about the tentative date of visit. The tools and equipment to be taken on the field visit may be:

- Copy of project request form;
- Project identification questionnaire;
- Topographical maps;
- Note books and necessary stationary;
- GPS;
- Stop watch;
- Calculator;
- Camera;
- 3 m long measuring tape

### **2.2.4 Analysis and Reporting**

Based on the data and information collected during the field visit the team needs to analysis the project findings and finalize the identification study. The analysis should be based on technical, economical and social aspects of project implementation. The analysis may cover the following aspects:

- Length of main canal;
- Size and type of command area (terrace/plain);
- Water right problems;
- Type of soil;
- Major technical difficulties (cross drainage/landslide/unstable zones);
- Poor farmer's presence;
- Farmer's interest

Based on the analysis the team has to prepare a report stating the project recommendation for further actions. The recommendation may be based on:

- Genuineness of demands;
- Command area
- No technical complication
- Year round irrigation water availability and no water dispute;
- Potential for increased agriculture production;
- No environmental adverse effect
- Rehabilitation schemes/ schemes requiring relatively minor improvements

## **2.3 Feasibility study**

### **2.3.1 Introduction**

The feasibility study is basis for project implementation and is carried out by a team of experts having engineering, agriculture, and socio-economic professionals. This study normally forms the basis of financing by external funding agencies or by the Government. The study assesses the technical feasibility, economical viability and institutional suitability of the project implementation. The feasibility study is carried out in the following steps:

- Desk study
- Field survey work
- Field data analysis
- Outline design
- Cost estimate
- Economic analysis
- Project reporting and recommendation

### **2.3.2 Desk study**

The desk study is a review of the work carried out at the project identification stage. This study needs to see generally two aspects.

- List of outstanding matters to be studied, and
- Any possible scheme alternatives

There may be several outstanding issues not touched during previous studies, which should be addressed during feasibility study. The scheme alternatives need to be reviewed in the feasibility study, which may include the following:

For new schemes:

- Alternative water sources from different rivers, pumped supply, ground water, supplementary rivers, etc
- Alternative intake site on one river
- Alternative canal alignment

For rehabilitation schemes:

- Extension of command area
- Combining several schemes
- Revised canal alignment
- Revised intake site

### **2.3.3 Field Survey Work**

The field survey work may differ slightly based on the type of the scheme whether it is new or rehabilitation. The following are the main activities to be carried out during the field survey work:

- Cutting a trace along the canal line for new scheme
- Intake site survey
- Discharge measurement
- Canal alignment survey
- Long section
- Work inventory
- Major structure site survey
- Command area survey (GPS survey)
- Conceptualize the Irrigation System and seek opinion of Farmers

- Agricultural survey
- Socio-economic survey
- Environmental survey etc

### 2.3.4 Field data analysis

The collected data and information has to be analyzed, on return to the office, before the final decision can be taken on the project:

#### i. Command area

Estimation of gross command area is often difficult to work out. Following methods can be used to find the command area.

- Data obtained from the farmers
- From topographic map
- From project identification study
- Use of GPS

#### ii. Scheme water balance

Before starting the canal design, it is important to check the water balance to conform whether variable water is sufficient to the proposed command area in all seasons. Following are the steps to follow:

- Determine future cropping pattern- crops, planting, dates and harvesting dates;
- Calculate the irrigation water requirement for each time period(15 days);
- Assess the effect on the irrigation water requirement by adjusting the cropping pattern on time period forward and backward;
- Measure the catchment area in the intake sites from the topography maps;
- Calculate the 80% reliable flow by measuring the river discharge at the intake site and the hydrographs of the area;
- For each time period, compare the irrigation water requirement with 80% reliable flow to check the availability of water;
- Adjust the cropping pattern, calculate irrigation water requirement for it and check the availability of water. Repeat this method and determine the optimum command areas;
- For each crop, determine the maximum area that can be irrigated. If the whole area cannot be reliably irrigated command should be reduced. If necessary, alternative cropping pattern to allow a larger irrigable area for the winter and spring crop should be discussed with district agricultural office.

#### iii. Feasibility design

##### a. System layout

Using topographic maps a plan of the system should be made showing the source, primary canal alignment, major structures and main part of the command area. A schematic line diagram of system layout need to be prepared;

##### b. Canal design

For feasibility level design, typical canal cross sections can be related to canal discharge and ground conditions. For rehabilitation designs, canal designs, canal design are only required for reaches where complete remodeling is needed.



- c. Structure design  
It should be prepared for intake and major structures. For minor structures typical standard drawing may be used
- d. Standards for feasibility level design
  - Head Works: Sketches (Plan, typical section) showing location and levels and dimensions should be prepared and principal quantities estimated,
  - Layout: A layout plan of the scheme and command area showing primary and secondary canal alignment should be prepared,
  - Canals
    - Canal routes, capacities , slope, levels and dimensions should be established,
    - A longitudinal section of the canal should be prepared,
    - Typical cross sections should be drawn,
    - Earthwork quantities should be worked out,
  - Structures
    - Drawings of the typical structures should be prepared,
    - Each size and type of structure should be assessed,
    - Drawings of major structures showing location, levels and dimension should be prepared,
    - Principal quantity should be calculated,

## 2.4 Topographical Survey

Topographical survey is the process of determining the position both in plan and elevation of natural features of the area. The extent of topographical survey depends upon the size, type, and level of the project study and includes:

- Benchmark survey,
- Traverse survey,
- Alignment survey, and
- Longitudinal and cross sectional survey

The topographical survey standard for small scale irrigation schemes may be as follows (Table-2.1).

**Table 2-1: Topographical Survey Standards**

S.N	Principal use	Details
1	Scheme identification	<ul style="list-style-type: none"> <li>• Use existing maps but supplement with site inspection</li> </ul>
2	Feasibility study	<ul style="list-style-type: none"> <li>• Use existing maps, site sketches,</li> <li>• Carry out traverse survey (GPS),</li> <li>• Benchmark survey (0.50 km interval in the hills and 1.0 km interval in Terai),</li> <li>• Carry out detailed site survey for structures-intake/headwork, major structures</li> <li>• For command area topographical survey take 100 m interval grid for contour interval of 0.25m in Terai and 0.50 to 1.0 m in the hills</li> <li>• Carry out canal alignment survey with I-section and x-sections</li> </ul>
3	Construction stage	<ul style="list-style-type: none"> <li>• Use design drawings,</li> <li>• Check and agree levels and dimensions,</li> <li>• Carry out additional survey for details of the site if required</li> </ul>

## 2.5 Hydrological survey

Hydrological survey is carried out to provide data and information for the assessment of water availability for irrigation, and assessment of flood flows for the intake/headwork and cross drainage works. The data and information includes are flow measurement, catchment area size, conditions of catchment, river or drainage sections and profile. The general land use pattern of the catchment area may also be collected during this survey.

## 2.6 Socio-economic Survey

The socio-economic survey is carried out to determine the social structure of the community and its economic status. The survey includes the collection of quantitative and qualitative data and information on social structure, socio-cultural institutions, and economic activities of the farmers of the scheme command area. Some of social and economic indicators of the community are as follows:

Social indicators:

- Willingness/commitment- verbal request, formation of committee, submission of request form;
- Ethnic composition- homogeneity, diversity;
- Education- literacy, school and college, awareness about irrigated agriculture, prior experience on irrigation;
- Rural organization- Parma, Guthi, etc;
- Family size- male/female, economically active members,
- Migration- temporary, permanent, foreign/urban areas;

Economic indicators:

- Land holding size- land less, marginal land (< 1 ha), land lords(> 5 ha);
- Main occupation- agriculture, service, labor, foreign service, business;
- Source of income- agriculture, service, remittance etc;
- Expenditure- food, cloth, schooling, festivals, livestock, agriculture

LILI/HELVETAS has developed socio-economic and technical survey formats for the pre-feasibility study and detail study of small irrigation schemes. These formats can be used for the survey and study of small irrigation schemes and hence annexed for reference (Annex:2-1 and Annex:2-2).

## 2.7 Agricultural Survey

For small irrigation schemes agricultural survey may include data and information regarding the soil type, land use and agriculture practices of the command area to be proposed. The soil survey may include the assessment of the type of soil in the command area and its suitability for irrigated agriculture. The soils may be alluvial, sandy, gravel and boulder mixed.

The land use survey may include the general assessment on land use in the command area which may classify in percent the agricultural land, forest land, grazing land, wetlands, National Parks and reserve forest area.

The agriculture survey includes the collection of data and information on:

- Existing cropping pattern,
- Existing crop yields,
- Inputs used and its availability,
- Marketing facility and labor situation

With the completion of detail feasibility study of the scheme studied, the compiled report should prepare and the report shall comprise the following headings:

- Analysis of Irrigation Scheme Area:
  - Scheme area Background
  - Location and Accessibility
  - Geological and Environmental Aspects
  - Lay Out of the Scheme
- Technical Survey:
  - Location and condition of Water Source(s) and Assessment
  - Description of proposed Structures
  - Availability of Construction Material and Labors
- Socio-economic and Agricultural Survey:
  - Social and Economic Situation
  - Agricultural Situation (existing and proposed command area, cropping pattern and intensity)
  - Availability and Linkage to agricultural Service Providers
- Detail Cost - Estimate
  - Approved District Rates and Rates at the Sites
  - Rate Analysis
  - Abstract of Cost and Bill of Quantities
  - Summary of Labor and Materials
- Economic Analysis
  - Crop Budget without and with Irrigation Scheme
  - Benefit/Cost Ratio and Economic Internal Rate of Return (EIRR)
- Conclusion and Recommendation:
- Annexes:
  - Details of compiled data, Designs and Calculations
  - Working Drawings
  - Minutes of Community Meetings and Consent Letters of Land Donation
  - Photographs of sites/location (Intake, command area, Alignment, community meeting)
  - Soft Copy of GPS data

For the preparation of design report, refer *Guidelines for Detail Survey, Design and Cost Estimate Report of Small-scale Farmer Managed Irrigation System*.

### 3. Hydrological Analysis and Water Requirement Assessment

#### 3.1 Maximum Design discharge

The criteria for the selection of maximum design discharge are based on technical and economic considerations. The major criteria for the selection of design flood are:

- Importance of structure to be constructed,
- Effect of overtopping of the structure,
- Potential loss of life and downstream damage, and
- Cost of the structure

Books on Hydraulic Structures and manuals have suggested the return period as below (Table-3.1). There are various methods of estimating maximum design discharge or design flood.

**Table 3-1: Suggested Return Period**

S.N	Type of structure	Return Period in years
1	Irrigation supply reliability	5
2	Road culverts	5-10 years depending upon the type of crossings
3	Highway bridge	10-50 years depending upon the type of rivers
4	Irrigation intake	10-25 years
5	Irrigation weir/barrage	50-100 depending upon its size
6	Cross drainage structures	10-25 years

#### 3.2 Flood Frequency Analysis

The flood frequency analysis is a statistical method to show that flood events of certain magnitude may on average is expected once every n year. It is generally carried out to estimate the design flood from the recorded flow data of more than 10 years. The most commonly used methods for frequency analysis are:

- Gumbel's distribution,
- Log Pearson –III distribution, and
- Log Normal distribution

The details of these methods are available in the Handbook of Applied Hydrology by Vent Te Chow, 1964.

#### 3.3 Regional Analysis

When the recorded hydrological data of the river is absent or too short a regional analysis is adopted to estimate the flood flow, and low flow of required return periods. In this method a hydrological homogeneous region is considered from statistical point of view. There are various methods of estimating flood flow of given return period based on regional analysis. In Nepal following methods are used to estimate the flood flow:

- WECS/DHM (1990) Method- based on regression analysis,
- Tahal et al (2002) Method – based on Index Flood Method,
- Sharma and Adhikari (2004) – based on regression analysis

In addition, there are rational method and empirical methods such as Modified Dickens method, Ryve's method. The most commonly used methods in Nepal is Sharma and Adhikari Method based on regional analysis and Rational Method as empirical method.

### 3.3.1 Sharma and Adhikari Method

This method is derived using hydrometric data of DHM up to 1995 and is considered the updated version of WECS and DHM Method. The formulae are as follows:

$$Q_2 = 2.29 A_{300}^{0.86}$$

$$Q_{100} = 20.7 A_{300}^{0.72}$$

Where;

$Q_2$  = 2 year flood

$Q_{100}$  = 100 year flood

$A_{300}$  = Catchment area below 3000 m altitude

For estimating the floods of other return periods, the relationships shown in the WECS and DHM Method can be used. Hence, the 50 year return period flood ( $Q_{50}$ ) is estimated as follows:

$$Q_{50} = \exp \ln Q_2 + 2.045 \left( \ln \frac{Q_{100}}{Q_2} / 2.326 \right)$$

### 3.3.2 Rational Method

The Rational Method is a widely used method for flood flow estimation of small sized-basins. The rational method formula is as follows:

$$Q = 0.278 CIA$$

Where,  $Q$  = peak discharge in m<sup>3</sup>/s

$C$  = runoff coefficient (roughly defined as ratio of runoff to rainfall)

$I$  = rainfall intensity in mm/h

$A$  = catchment area in km<sup>2</sup>

For the natural catchments, the values of  $C$  vary from 0.2 to 0.4. The average rainfall intensity  $I$  has a duration equal to the critical storm duration, normally taken as a time of concentration. Rainfall intensity-duration-frequency data normally is used to estimate the rainfall intensity ( $I$ ). If such data are not available, the value of  $I$  is taken to be between 60 to 70 mm per hour for small catchments in Nepal. These values are comparable to other studies in Nepal and they correspond to about 50 year return period maximum rainfall intensity.

## 3.4 Water Availability for Irrigation

### 3.4.1 General

The assessment of water availability for irrigation is carried out on 80% reliability of full supply. This means 80% of the time there is at least enough water available to meet full demand of irrigation. For gauged river the reliability assessment is carried out by frequency analysis while for ungauged river regional regression analysis for long term mean flow is adopted in Nepal.

### 3.4.2 Frequency Analysis

For gauged sites the 80% reliable monthly flows are obtained using the following formula:

$$Q_{80} = Q_{mean} - 0.8418S$$

Where;  $Q_{80}$  = 80% reliable monthly flow in  $m^3/s$   
 $Q_{mean}$  = mean monthly flow in  $m^3/s$   
 $s$  = standard deviation of the monthly series

The factor 0.8418 is the 1 in 5 reduced variate of the normal distribution assuming that the monthly flow series follows a normal distribution. In the case of the diversion site being near the gauged site, the monthly flows at the diversion site is calculated using an area ratio.

$$Q_d = Q_g \frac{A_d}{A_g}$$

Where,  $Q_d$  = monthly discharge at diversion site in  $m^3/s$ ,  
 $Q_g$  = monthly discharge at gauged site in  $m^3/s$ ,  
 $A_d$  = catchment area at diversion site in  $km^2$ ,  
 $A_g$  = catchment area at gauged site in  $km^2$

### 3.4.3 MIP Method

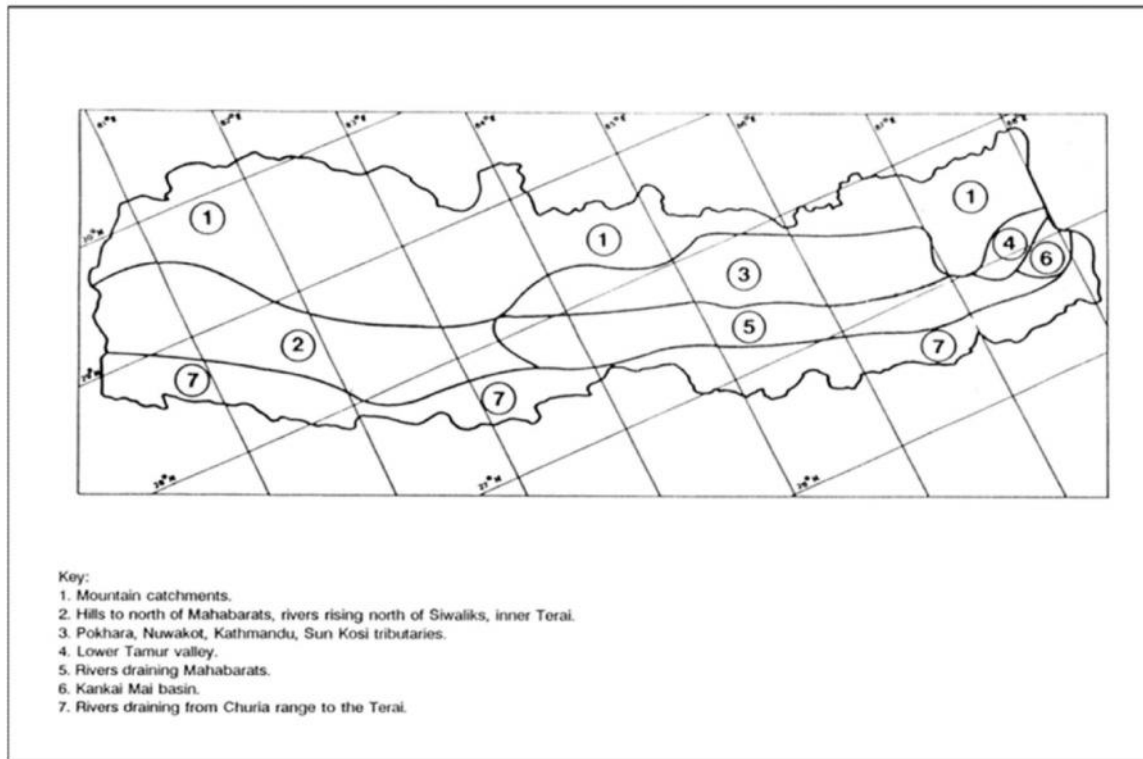
The Medium Irrigation Project (MIP) Design Manual (1982) has developed regional hydrographs using spot measurements of the ungauged rivers. This method is widely used in irrigation planning and design in Nepal. The country has been divided into seven hydrological regions (Figure 3.1); each region has a monthly hydrograph showing mean, 20% reliable and 80% reliable flows. The ordinates of the regional hydrographs have been non-dimensionalised by dividing each by the April flow. For using the non-dimensional hydrograph to predict the mean and 80% reliable flows, it is essential to measure the flow at site during dry season (September to May) to eliminate the influence of storm flow. The detail of MIP method can be found in PDSP Manual M3.

## 3.5 Discharge Measurement

### 3.5.1 General

The amount of water passing a point on the stream channel during a given time is a function of velocity and cross-sectional area of the flowing water and is expressed by Continuity equation:  $Q=AV$ , where  $Q$  is the stream discharge,  $A$  is cross-sectional area, and  $V$  is flow velocity. Discharge measurement follows the continuity equation which is concerns with the measurement of the flow velocity. For small irrigation schemes, three methods are appropriate for discharge measurement: Float method, Bucket and watch method and Current meter method.

**Figure 3-1: Hydrological Regions of Nepal**



### 3.5.2 Float method

This method measures surface velocity of flowing water. Mean velocity is obtained using a correction factor. The basic idea is to measure the time taken to float the object in a specified distance.

$$V_{\text{surface}} = \text{travel distance} / \text{travel time} = L/t$$

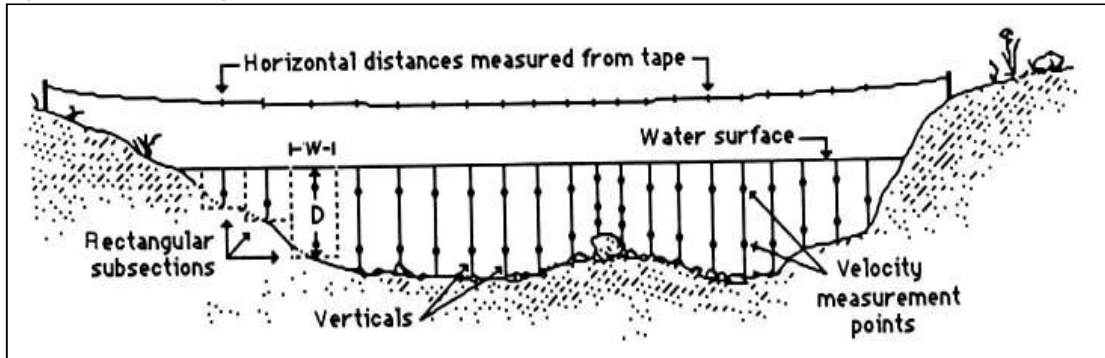
Because surface velocities are typically higher than mean or average velocities,  $V_{\text{mean}} = k V_{\text{surface}}$  where  $k$  is a coefficient that generally ranges from 0.8 for rough beds to 0.9 for smooth beds (0.85 is a commonly used value). In mountain streams with lots of roughness elements, the value may be much lower e.g. 0.67.

The procedures for discharge measurement are as follows:

- Step 1: Choose a suitable straight reach with minimum turbulence (ideally at least 3 channel widths long);
- Step 2: Mark the start and end points of the chosen reach;
- Step 3: If possible, travel time should exceed 20 seconds but be at least 10 seconds;
- Step 4: Drop your object into the stream upstream of the upstream marker;
- Step 5: Start the watch when the object crosses the upstream marker and stop the watch when it crosses the downstream marker;
- Step 6: Repeat the measurement at least 3 times and use the average in further calculations;
- Step 7: If you only do the float method you need to measure the cross-sectional areas at the start and end point of your reach.
- Step 8: Average cross-sectional areas;
- Step 9: Using the average area and corrected velocity, you can now compute discharge,

$$Q = AV$$

**Figure 3-2: Discharge Measurement with Float Method**



### 3.5.3 Bucket and Watch method

Bucket and watch method is simple volumetric measurement of water at the given time period. This method is applicable for spring source having discharge less than 1 lps. A plastic bucket or any vessel can be used to measure the volume of water by diverting the entire flow into measuring vessel of known capacity. The time taken to fill up the vessel is noted. At least three to five readings are necessary for the measurement of the water and average value is computed. The discharge calculation may be carried out using following format (Table-3.3).

**Table 3-2: Discharge Measurement with Bucket-Watch Method**

Project name:		Location:				
Source name:		Date of measurement:				
Description		Measurement number				
A	Vessel capacity (liter)	1	2	3	4	5
B	Time to fill the vessel (sec)					
C	Discharge (l/s) = A/B					
D	Average discharge Q (l/s)	$Q = (C1 + C2 + C3 + C4 + C5)/5$				

### 3.5.4 Current Meter

Current meter is a device used to measure the velocity of flowing water. It has a propeller mounted on a shaft which allows moving freely to the propeller at any depth of water. The speed of rotation is the function of the velocity of water. The manufacturer of current meter provides correlation between number of rotations and velocity of water. The measurement of velocity is more accurate and reliable and the current meter is extensively used in streams having uniform cross sections.

## 3.6 Water Requirement Assessment

### 3.6.1 Crop Water Requirements

The crop water requirement is defined as the quantity of water utilized by the plant during its lifetime. It is estimate with evapo-transpiration (ET<sub>o</sub>) of reference crop. The steps used to calculate the crop water requirements are as follows:



- I. Decide cropping pattern,
- II. Calculate reference crop evapo-transpiration (ET<sub>o</sub>) (from FAO methods and tables),
- III. Use crop coefficients (from FAO),
- IV. Calculate evapotranspiration of crops ET<sub>crop</sub> (mm/day)
- V. Allow for land preparation (rice and wheat only) loss (L<sub>p</sub>),
- VI. Allow for deep percolation (rice only)(d<sub>p</sub>),
- VII. Calculate evaporation from land preparation (rice only)(E<sub>o</sub>),
- VIII. Calculate total crop water requirements (CWR),
- IX. Calculate effective rainfall (P<sub>e</sub>),
- X. Calculate net crop water requirements (net CWR),

The detail of crop water requirement can be referred on PDSP Manual, M3.

### 3.6.2 Irrigation Water Duty

The duty of irrigation water is the amount of water required for irrigation of unit land area for specific crop. The duty of irrigation water depends upon:

- Type of crop grown;
- Climate season;
- Type of soil, and
- Efficiency of cultivation methods

In Nepal water requirement practices vary significantly. In the hills and mountains FMIS water requirement is as high as 5.0 lps/ha, while it is up to 4.0 lps/ha in Terai. For the design of small irrigation schemes the following water requirement values are suggested (Table-3.7).

**Table 3-3: Irrigation Water Duty**

Soil type	Water requirement (lps/ha) at field	
	Terai schemes	Hill schemes
Clay soil	1.5	2.0
Loamy soil	2.5	3.0
Sandy loam soil	4.0	5.0

*Source: Pokhrel, 1998*

Water requirement at Head works (diversion point) = Water requirement at field + Conveyance loss

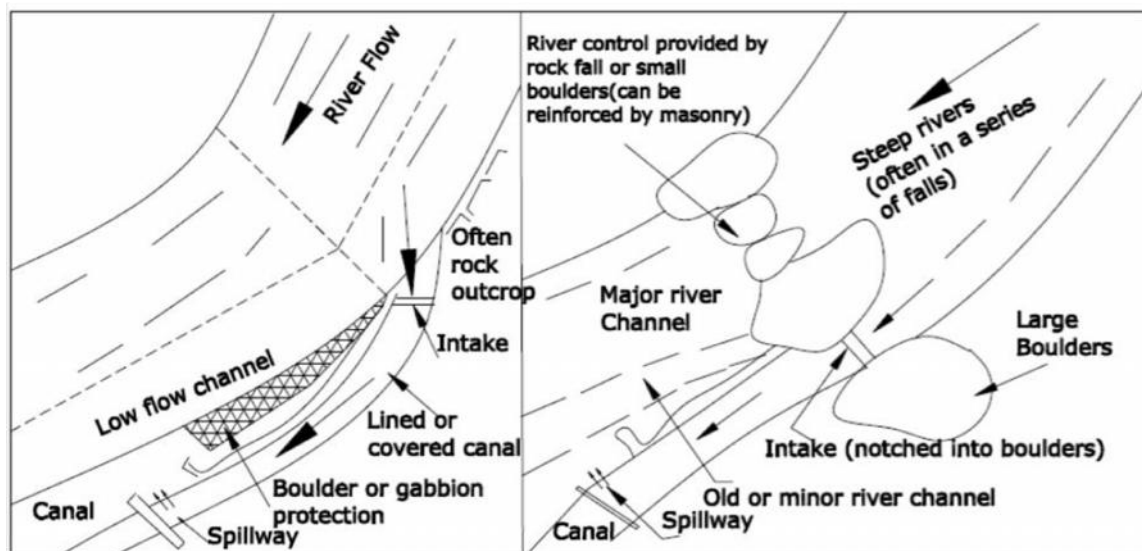
## 4. Diversion Headworks and Intakes

### 4.1 Selection of Site for Headwork or Intake

The selection of site for the headwork or intake relates to ensure the required flow to be diverted to the canal at all stages of the river. The main considerations in the selection of the headwork or intake site are as follows:

- Channel dimensions- narrow floodway with a relatively straight approach reach, enabling the river to develop linear flow,
- Thalweg deflection- the main channel with low flow is referred as thalweg. The stability of thalweg is the prime importance in selecting the suitable intake sites,
- Outside of a bend- at the outside of bend secondary currents develop which reduce the entry of bed load into the intake and deflect the bed currents away from the intake (Figure 4-1),
- Confluence of two rivers- at the downstream of the confluence of two rivers the intake location is mostly suitable,
- Boulder deposits- in steep rivers boulder deposits occur when river emerges from the gorge and at its downstream river bed is stable due to reduced tractive force,
- Bank stability-banks with rock outcrops, or armored boulder banks protect the intake from erosion,
- River slope-intake location is stable at pool reach of the river slope,
- Stable geological section- intake is stable where geology is stable.

Figure 4-1: Layout of side intake on hills and Mountain Rivers



## 4.2 Types of Intake

The main types of intakes are:

- Side intake with no river controls;
- Side intake with simple stones or brushwood weir;
- Side intake with some form of river controls;
- Parallel side intake with spur wall;
- Intake from behind the boulder; and
- Bottom intake

## 4.3 Design of Simple Side Intake

The design of simple side intake for small scale irrigation systems in the hills consists of:

- Design of feeder canal, and
- Sizing of an orifice to pass the desired discharge

The feeder canal shall have capacity of surplus discharge for flushing the sediments from sand trap or de-silting basin. The orifice with or without gate is provided on the headwall having sufficient height to protect the canal from flood entry. The sizing of orifice opening will consider the required discharge to pass and to control the entry of flood flow (Figure 4-2).

The basic hydraulic design for a simple intake will depend on the size of sediment and hence on the desirable nominal trap velocity. The basic design parameters of the side intake are presented hereunder (Table-4.1).

**Table 4-1: Velocity and Head Losses across Gravel Traps**

Description	Coarse Sand	Fine/medium gravel	Medium/coarse gravel
	Velocity (m/s)		
Nominal trap velocity	0.15	0.25	0.50
Sill velocity	0.15	0.25	0.50
First orifice velocity	0.25	0.42	0.83
Outlet gate velocity	0.60	0.60	0.60
	Head Loss (mm)		
At sill	3	8	32
At first orifice	8	22	88
At outlet gate	46	46	46
Total head loss	57	76	166
Take total head loss	60	80	170

Source: PDSP Manual, M-7, 1990

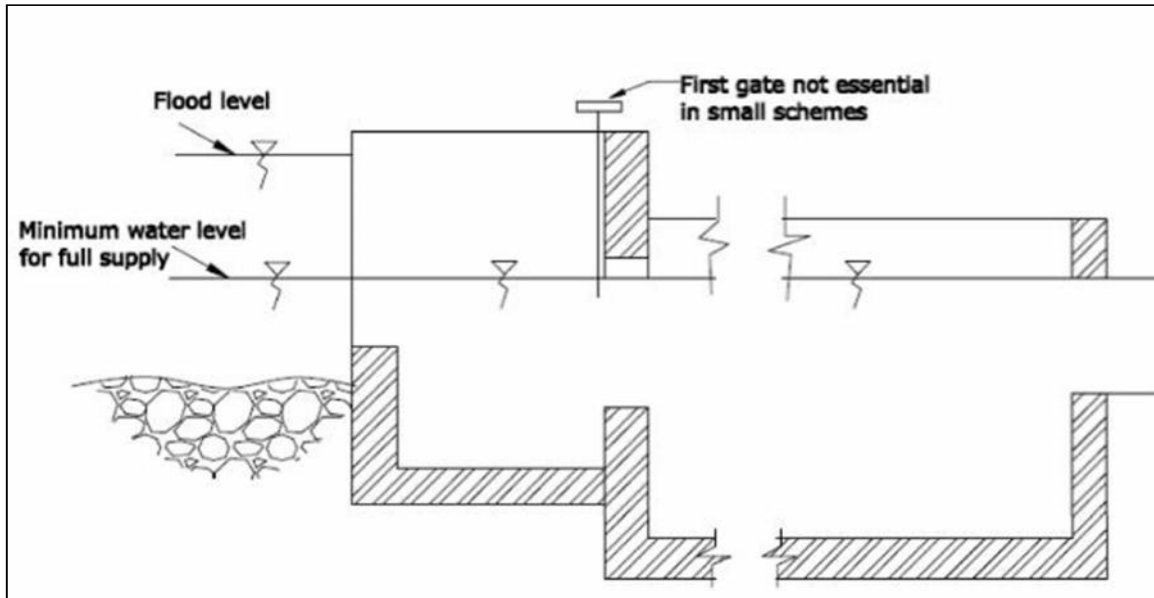
The discharge through orifice can be calculated using formula:

$$Q = CBD \sqrt{2g\Delta H}$$

Where, Q = discharge through orifice, m<sup>3</sup>/s

$B$  = orifice width, m  
 $D$  = orifice height, m  
 $\Delta h$  = orifice head loss, m  
 $g$  = acceleration due to gravity, ( $m/s^2$ )  
 $C$  = discharge coefficient = 0.7

**Figure 4-2: Side intake with two orifices**



## 4.4 Bottom Intake

### 4.4.1 General

A bottom intake captures the water from the bed of the river. It is a run-of-the-river diversion structure which diverts stream flow by allowing water to drop into the trench constructed transverse to the stream flow. It allows the diverted water to flow through an orifice to the main canal. This type of intake is mostly suitable in hilly region and also termed as Bottom Rack Intake. The main components of a bottom intake are:

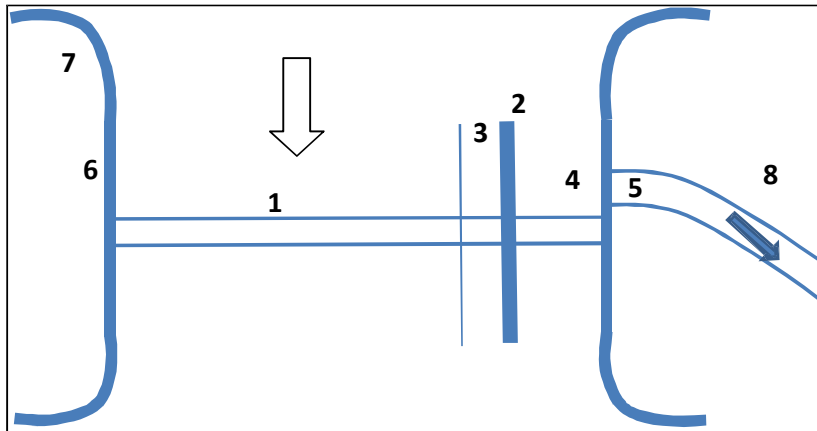
- Weir to control minimum river flows and to maintain the flow towards the rack,
- Steel rack to extract water from the river,
- Bottom trench immediately below the rack to lead the water extracted by the rack into the canal,
- Flood control gate immediately downstream of the trench,
- Feeder canal to carry all sediment entering the intake to the settling basin,
- Settling basin with a side spill and sediment flushing arrangement,

## 4.5 Diversion Weir

### 4.5.1 General

The diversion weir is simple hydraulic structure across the river to maintain the pond level at its upstream which needs careful design with respect to hydrologic, hydraulic and structural analysis. According to the material of construction weirs may be grouped as masonry weir, concrete weir and gabion weir. According to the shape of crest the weirs are classified as vertical drop weir, Ogee weir, broad crested weir, and sharp crested weir. The layout of the diversion weir and its components are presented hereunder (Figure-4.2).

**Figure 4-3: Layout of Weir and its Components**



1. Weir
2. Divide wall
3. Fish ladder for large weir
4. Under sluice
5. Head regulator
6. Abutments
7. Guide bund
8. Canal

The design of weir consists mainly two parts: hydraulic design and structural design. The design of weir shall decide the following parameters:

- Lacey's silt factor,  $f = 1.76\sqrt{D_m}$  Where,  $D_m$ - average size of sediment particle in mm;
- Length of waterway, discharge intensity and afflux;
- Safe exit gradient;
- Depths of cutoffs in relation to both scour depth and exit gradient;
- Level and length of downstream horizontal floor;
- Thickness of downstream horizontal floor with reference to uplift pressure and hydraulic jump;
- Length and thickness of protection works

### 4.5.2 Crest Level of Weir and Under-sluice

Fixation of crest level of the weir is governed by two factors: the required command level of the canal and to divert the low flow of the river during dry season. If minimum flow of the river exceeds the design discharge of the canal the crest level of weir is set at lower than the water level of the river. The crest level of the under sluice is fixed at the lowest bed level of the river in the deepest channel. The crest level of the under sluice is generally kept 1 m below the crest of the weir in small and medium rivers.

### 4.5.3 Length of Weir and Afflux

Length of weir has direct correlation with the afflux and discharge intensity of the weir. Longer the length smaller be the discharge intensity. The length of weir also depends upon the topography of the weir site, state of river, and provision of energy dissipation at downstream end. Lacey has provided formula for waterway as wetted perimeter:

$$P = 4.83 \bar{Q} \text{ Where, } Q \text{ is high flood discharge in } m^3/s;$$

For boulder stage rivers this Lacey's formula may not work properly and designer has to judge considering the following main points:

- Average wetted width of the river during flood;
- Formation of shoals upstream of the weir;
- Energy dissipation devices downstream of the weir;

**Figure 4-4: Concrete weir and undersluice**

The discharging capacity of the broad crested weir is calculated as:

$$Q = 1.705 L - 0.1nH H^2 \text{ }^3$$

Where, L is total clear waterway in m, n is number of end contraction, H is head over the crest in m



### 4.5.4 Effect of Retrogression

Retrogression is the lowering of the river bed downstream of the weir in early stages after construction. In designing the weir the effect of retrogression needs to be considered. For small rivers the

retrogression is taken to be 0.30m to 0.50m.

#### **4.5.5 Hydraulic Jump**

Hydraulic jump occurs when super critical flow of water changes into the sub-critical flow. This is the most efficient method of dissipating kinetic energy of super critical flow of water. Hydraulic jump is stable in sloping glacis and hence it is essential to provide sloping glacis at the weir surface with slope ranging from 1:3 to 1:5. With the analysis of hydraulic jump following parameters are designed:

- Downstream floor level;
- Length of horizontal floor;
- Downstream protection works; and
- Uplift pressure

## 4.6 Gabion Weir

### 4.6.1 Gabion weir

Gabions weir have been used extensively in the past, for irrigation headworks, but the result has not been encouraging. The gabion weirs are vulnerable to damage by boulders moving during floods, and after a few wires are broken the entire gabion structures may collapse. Most of the gabions weirs constructed in hill irrigation systems in Nepal stand for only one or two years and the performance is very poor. Instead of providing the facility to abstract the water, it creates problems of outflanking and degrading the river bed when it is washed away by the floods. Gabion weirs are suitable in streams with gentle slope and stable bed conditions usually sandy and muddy. It is nearly impossible to find such kind of situation in the hilly rivers of Nepal. Hence, gabion weirs basically are semi permanent structures and their use could be limited in the following three locations at head works:

- For river bed control;
- To make an orifice controlling the amount of water diverted into the intake; and
- As protection for the inlet structure from erosion by flow over the spillway and from the gate.

Compared with masonry, gabions have the advantage of a degree of flexibility, but as described above, they must be considered as semi permanent structures. They cannot be designed to withstand such high discharge intensities as permanent structures, nor can they have life of more than 10 years or so years in gravel bed rivers bearing in mind the gabion weirs' vulnerability to breaking and corrosion. The economy of gabions is in the use of local stones found on the stream itself. The saving in capital cost is, however, offset by additional maintenance costs and the inevitable rebuilding.

If properly constructed, gabions could be suitable for use in reaches of rivers, which are sometimes unstable, with flood flows causing movement of the riverbed. Gabion weirs may be constructed as simple gravity weirs with alternative downstream arrangements:

- With a downstream sill or counter-weir
- With both a stilling basin floor and downstream sill
- With depressed stilling basin floor and flexible apron

Gabions are highly permeable, and when used for hydraulic structures, require particular attention to ensure the foundation material is not washed out a common cause of failure of gabion structures is due to the filter layers being inadequate.

A filter of impermeable membrane must be constructed underneath the gabions. The preferred form of filter is a synthetic fabric ( a type of geotextile). Alternatively a sand and gravel filter may be used. The sand layer should be at least 150 mm thick.

Failure of gabions may also occur by the wire cage through the impact of stones and boulders carried over the weir. Stepped weirs are not suitable for small channels with low flows and light bed load. The weir crest may need protection with a concrete coping. A gravel and rock fill against the upstream face of the weir is recommended.

Gabions must not simply be laid on existing bed of banks surfaces; they require proper foundations as would be required for masonry weirs.



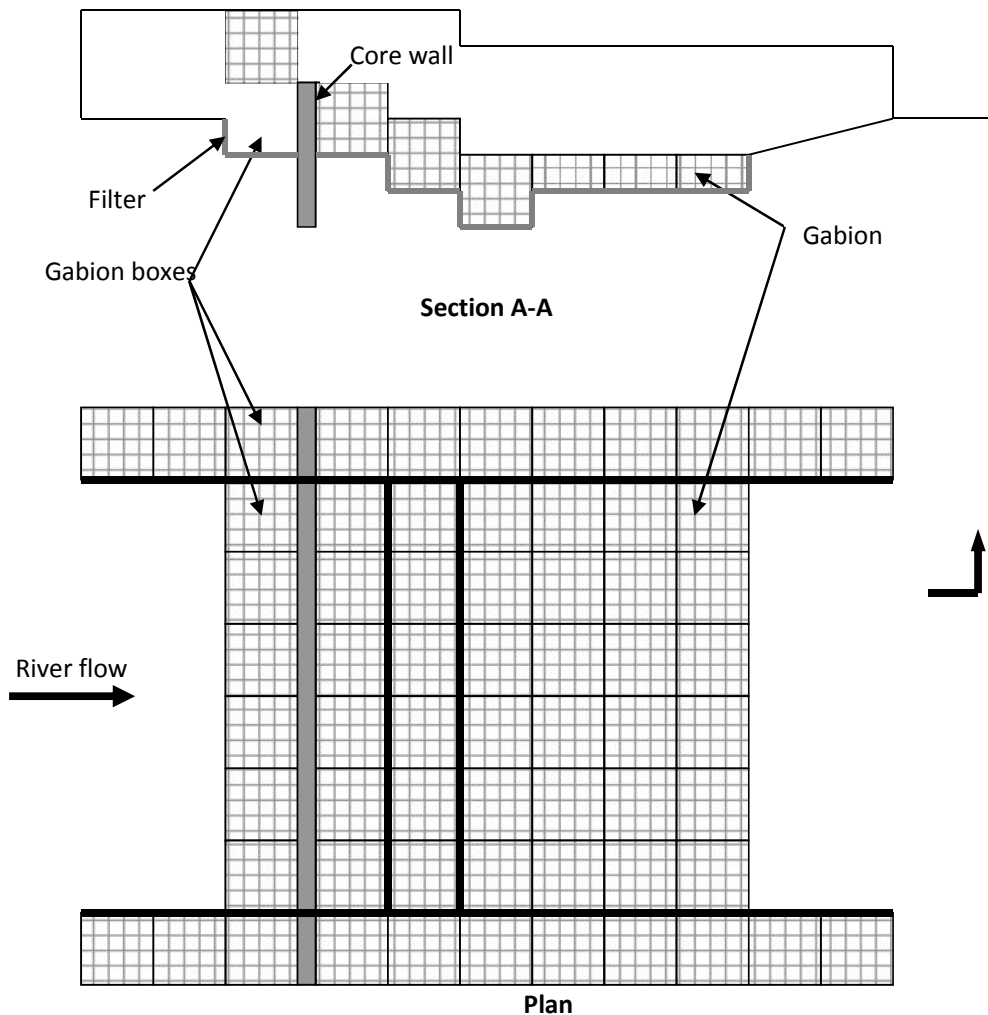
**Comments:**

The best results for this type of construction are obtained by exercising the utmost care in the filling of the gabions and in arranging their layout in courses in such a way that the distribution of the mesh in the structure is balanced with respect to its characteristic functions.

The deformation caused by shear can be effectively reduced by increasing the number of panels aligned perpendicular to the face of the wall and therefore parallel to the soil thrust and water thrust. Every effort shall be made to keep voids and bulges in the gabions to a minimum in order to ensure proper alignment and neat square appearance.

Well constructed gabions with proper panels inside are monolithic and continuous. Compression and shear tests conducted by MACCAFERRI have shown that gabions could withstand a compression load of 300 to 400 tons per square meter. The deformation of gabions is mainly due to shear stress developed in the boxes. The values of shear modulus of elasticity were found varying from 25 to 40 ton per square meter. (MACCAFERRI, Nepal Pvt. Ltd).

**Figure 4-5: Plan and Section of a Gabion Weir**



## 5. Canal Design

### 5.1 Design Concept

The design of irrigation canal involves:

- Determination of canal capacity;
- Determination of cross sectional parameters;
- Determination of bed level and slope of alignment;

For large irrigation system canal design of capacity starts from the field level to main canal and up to intake. For small scale irrigation the design of canal capacity may be carried out by:

$$Q = \text{NCWR} \times \text{CCA} / 8.64$$

Where, Q – design capacity of canal at the intake in lps;  
 NCWR – net crop water requirement in mm/day  
 CCA – cultural command area in ha;

If crop water requirement is not assessed, the capacity of canal can also be determined by the duty of irrigation water.

$$Q = \text{Duty} \times \text{CCA}$$

Where, duty or water requirement in lps/ha;

Example: Duty = 3 l/s/ha; CCA = 20 ha;  
 The capacity of canal (Qd) = 3 x 20 = 60 l/s

Canal cross sectional parameters are bed width, water depth, side slope, roughness coefficient, and free board. The longitudinal slope of the canal is determined based on the size of the canal and topography of the alignment.

## 5.2 Design of Unlined Canals

### 5.2.1 Design Procedure

The design of unlined canals is carried out by various methods. For small irrigation schemes it may be appropriate to use Manning's formula. The design procedure of the canal follows a series of steps:

- Determine the design discharge, Q;
- Determine the design side slope, m (1 vertical: m horizontal);
- Determine canal velocities, V;
- Determine bed width to depth ratio, r (r = B/D; B being bed width and D being water depth);
- Calculate area of flow, A = Q/V;
- Calculate depth of flow,  $D = \frac{A}{r+m}$ ;
- Calculate bed width, B = r\*D and round it to nearest 0.05 m;
- Calculate hydraulic radius, R = A/P or  $R = \frac{D(r+m)}{r+2\sqrt{m^2+1}}$ ;
- Determine roughness coefficient, n;
- Calculate slope of the canal, S, using Manning Formula,  $S = \frac{v^2 n^2}{R^3}$
- Check the slope with permissible Tractive Force and existing topography.

The design of various sections of the canal may be carried out in excel sheets. Various parameters of The

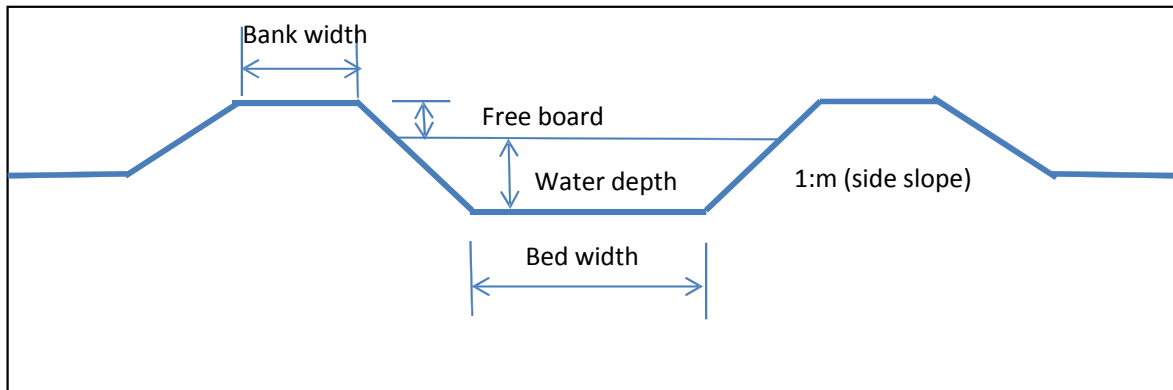
design of various sections of the canal may be carried out in excel sheets. Various parameters of canal design are briefed in the forthcoming headings.

### 5.2.2 Side Slopes

The side slopes for the trapezoidal canal section (Figure 5-1) is determined on the basis of slope stability of soil. The side slope should minimum as far as possible. If the canal in fill the side slope should be slightly flatter than in cut sections. Following are recommended side slopes of the canal.

Soil type	Side slope (m) (vertical: horizontal)
Hard rock	1:0.25
Soft rock	1: 0.50
Heavy clay	1:0.50 to 1:1
Loam	1:1 to 1: 1.50
Sandy loam	1:1.5 to 1:2

**Figure 5-1: Typical Canal Section**



### 5.2.3 Permissible Velocity

The optimum design velocity is chosen from the experience and knowledge of the soil conditions. The velocity should also be checked using the Tractive Force formula. The lower velocity allows to grow the weeds in the canal section than consequently decreases the canal capacity while higher velocity tends to erode the bed of the unlined canal. Hence, the velocity should be in permissible limits based on the type of soil, and capacity of canal. For unlined canals the velocity should be in between 0.45 m/s to 0.75 m/s.

The unit Tractive Force (T) is given by the equation:

$$T = CWRS$$

Where, C is the coefficient taken as 1 for bed and 0.76 for sides,  
W is the specific weight of water, 1000 kg/m<sup>3</sup>,  
R is the hydraulic radius of the canal section, m  
S is the water surface slope

The permissible Tractive forces of various soil conditions are presented hereunder (Table 5.1):

**Table 5-1: Permissible Tractive Force**

S.N	Material	Tractive Force (kg/m <sup>2</sup> )	
		Clear water	Silty water
1	Fine sand	0.13	0.37
2	Silt loam	0.23	0.54
3	Alluvial silts	0.23	0.73
4	Ordinary loam	0.37	0.73
5	Fine gravel	0.37	1.56
6	Coarse gravel	1.47	3.28
7	Cobbles and shingles	4.45	5.39

Source: PDSP Manual, Volume-M8, 1990

### 5.2.4 Bed Width to Depth Ratio

The bed width to depth ratio depends upon the capacity of the canal. For small irrigation canals having the discharge less than 0.50 m<sup>3</sup>/s the ratio is recommended to be unity. For discharges greater than 0.50 m<sup>3</sup>/s, wider canals could be provided if necessary.

### 5.2.5 Canal Slope

The canal slope is designed for non-silting and non-scouring velocity in canal and is calculated using Manning's Formula:

$$V = \frac{R^{2/3} S^{1/2}}{n}$$

Where, R is hydraulic radius =A/P, S is canal slope and n is roughness coefficient,

For small irrigation schemes the slope of the canal may limit up to 1:1500 in Terai and 1:500 in the hills. However, for existing FMIS the slopes may be steeper ranging from 1:100 to 1:500 depending upon the canal size, soil type, and topography.

The value of Manning's roughness coefficient depends upon the type of bed materials, condition of the canal and its geometry. The recommended values of n are presented hereunder (Table 5.2).

**Table 5-2: Values of Roughness Coefficient**

S.N	Description	Roughness coefficient, n
1	Earthen canal recently excavated	0.016 to 0.020
2	Gravel bed canal	0.022 to 0.030
3	Canal with short grass	0.022 to 0.033
4	Canal with dense weeds	0.030 to 0.040
5	Canals with earth bed and rubble sides	0.028 to 0.035
6	Canal with stony bottom and weedy banks	0.025 to 0.040

### 5.2.6 Free Board

Free board is difference of bank top level and full supply level of the canal. It is necessary to accommodate surplus discharge of canal coming from upstream reach. Free board depends upon the capacity of canal. The recommended values of free board are given below.

For Q less than 0.10 m<sup>3</sup>/s Fb=0.20 m;

For Q between 0.10 to 0.50 m<sup>3</sup>/s Fb=0.30 m

### 5.2.7 Minimum Radius of Curvature

The irrigation canal should be straight as far as possible from hydraulic point of view. However, in practice it is not possible to align straight canal and needs to bend the canal providing appropriate curvature. The minimum radius of curvature depends upon the canal capacity and topography. For small irrigation schemes the acceptable radius for unlined canal is taken from three to seven times of the water surface width. In rocky section the radius may be three times while it is larger in general types of soil.

### 5.2.8 Design Example of Unlined Canal

Data:

Command area = 20 ha,

Water requirement in hills = 5lps/ha

Soil type = ordinary soil

Calculation:

Determine design discharge (Q) = 20x5 = 100 lps = 0.1 m<sup>3</sup>/s

For ordinary soil take side slope (m) = 1:1

Take velocity of flow in canal (v) = 0.60 m/s

Determine bed width to depth ratio (r) = 1

Calculate area of flow A = Q/v = 0.10/0.60 = 0.17 m<sup>2</sup>

Calculate depth of flow,  $D = \frac{A}{r+m}$

D = 0.29 m, take D = 0.30 m

Calculate bed width (B) = rxD = 0.30 m

Calculate hydraulic radius (R)

$$R = \frac{D(r+m)}{r+2\sqrt{m^2+1}}$$

For ordinary soil and new canal take roughness coefficient, n = 0.0225

Calculate slope of the canal

$$S = \frac{V^2 n^2}{R^{4/3}}$$

S = 463.63 take S = 500

Adopt canal slope as 1/500 and verify with topography and existing condition

Check the velocity with adopted value of slope,  $V = R^{2/3} S^{1/2} / n = 0.58$  m/s which is within the limit,

Check Tractive force, T = CWRS = 0.31 kg/m<sup>2</sup> which is within the limit for ordinary type of soil

Hence, design is acceptable and canal parameters are:

- Bed width = 0.30 m,
- Water depth = 0.30 m,
- Free board = 0.15 m,
- Side slope (V:H) = 1:1
- Longitudinal slope = 1/500

The design of canal section is usually carried out in excel sheet with trial and error method.

## 5.3 Lining of Canals

### 5.3.1 Type of Canal Lining

Canals are lined to prevent seepage and leakage. There are various types of lining the choice of which is based on the purpose, nature of the scheme and availability of the material. The main features of the lined canal are presented in tabular form (Table 5-3).

**Table 5-3: Main features of lined canal**

S. N	Lining Type	Maximum Velocity (m/s)	Roughness Coefficient 'n'	Recommended thickness
1	Dry stone	1.0	0.025	20 cm to 50 cm
2	Dressed stone masonry	2.0	0.018	20 cm to 40 cm
3	Brick masonry	1.5	0.017	12 cm to 25 cm
4	Random rubble masonry (stone)	1.5	0.020	20 cm to 50 cm
5	Plain cement concrete or RCC	2.5	0.015	7.5 cm to 15 cm
6	Soil cement	0.75	0.02	4 cm to 9 cm
7	Ferro-cement	2.0	0.018	7.5 cm to 15 cm
8	Plastic	2.5	0.015	

Source: PDSP Manual Volume M 8, 1990

### 5.3.2 Design Concept of Lined Canal

Design of lined canal is carried out using continuity equation and Manning's formula considering as rigid boundary canal section.

Continuity equation,  $Q = A \times V$

Manning's formula,  $V = \frac{R^{2/3} S^{1/2}}{n}$

- Where,
- Q is design discharge of the canal in m<sup>3</sup>/s
  - A is area of cross section of the canal in m<sup>2</sup>,
  - V is the velocity of water in canal in m/s,
  - R is hydraulic radius in m =A/P,
  - S is canal slope and
  - n is roughness coefficient

The longitudinal slope for small canals depends upon the topography and existing condition of the canal. For rectangular section of canal the bed width to water depth ratio is taken as unity for design purpose. The side slope of the lined canal is zero in most of the cases. However, the lined canal may be of trapezoidal section with side slope ranging from 1:0.50 to 1:1.

### 5.3.3 Design Procedure of Lined Canal

The design procedure for the lined canal is almost same as that of unlined canal for small irrigation schemes.

- i. Determine the design discharge, Q;
- ii. Determine the design side slope, m (m is zero for rectangular section);
- iii. Determine canal velocities, V;
- iv. Determine bed width to depth ratio, r (r = B/D);
- v. Calculate area of flow,  $A = Q/V$ ;
- vi. Calculate depth of flow,  $D = \frac{A}{r+m}$ ; rectangular section with m=0 and r=1,  $D = \sqrt{A}$
- vii. Calculate bed width,  $B = rxD$ ;
- viii. Calculate hydraulic radius,  $R = A/P = A/(B+2D)$
- ix. Determine roughness coefficient, n;
- x. Calculate slope of the canal, S, using Manning Formula,  $S = \frac{V^2 n^2}{R^{\frac{4}{3}}}$ ;

### 5.3.4 Design Example of Lined Canal

Data:

Command area = 20 ha,

Water requirement in hills = 5pl/ha

Type of lining = stone masonry rectangular section

Calculation:

Determine design discharge =  $20 \times 5 = 100 \text{ lps} = 0.1 \text{ m}^3/\text{s}$

Take velocity of flow in canal,  $V = 0.75 \text{ m/s}$

Determine bed width to depth ratio  $r = 1$

Calculate area of flow  $A = Q/V = 0.10/0.75 = 0.13 \text{ m}^2$

Calculate depth of flow  $D = \sqrt{A}$

$D = 0.37 \text{ m}$ , take  $D = 0.40 \text{ m}$

Calculate bed width  $B = r \times D = 0.40 \text{ m}$  then  $A = 0.16 \text{ m}^2$

Calculate wetted perimeter  $P = B + 2xD = 1.20 \text{ m}$

Calculate hydraulic radius  $R = A/P = 0.13 \text{ m}$

For stone masonry lining take roughness coefficient,  $n = 0.018$

Calculate slope of the canal;

$$S = \frac{V^2 n^2}{R^{\frac{4}{3}}}$$

$$S = 373.75 \text{ take } S = 400$$

Adopt canal slope as 1/400 and verify with topography and existing condition

Check the velocity with adopted value of slope,  $V = R^{2/3} S^{1/2} / n = 0.72 \text{ m/s}$  which is within the limit,

Check Froude number  $F = V / (gxD)^{0.5} = 0.37$  which is within the limit (less than 0.50)

Hence, design is acceptable and canal parameters are:

Bed width = 0.40 m,

Water depth = 0.40 m,

Free board = 0.20 m,

Longitudinal slope = 1/400

The design of canal section is usually carried out in excel sheet with trial and error method. LILI has prepared two sheets for canal design: one for earthen canal and another for lined canal design (Annex: 5-1).

## 5.4 Design of Covered Canals

### 5.4.1 Design Concept

Covered canals are generally designed to be free flowing open channels like lined canal section. For the hydraulic computation, Manning's formula is used which is described in previous headings. Head losses in the transition between the open canal section and the covered canal section need to be considered during the design. The energy losses can be computed as:

$$H_i = \frac{C_i(V_p^2 - V^2)}{2g}$$

$$H_o = \frac{C_o(V_p^2 - V^2)}{2g}$$

Where,  $H_i$ ,  $H_o$  are the head losses at the inlet and outlet respectively in m,  
 $C_i$ ,  $C_o$  are loss coefficients for the inlet and outlet;  
 $V_p$  is the velocity in the covered section in m/s,  
 $V$  is the velocity in the open canal in m/s,  
 $g$  is the acceleration due to gravity = 9.81 m/s<sup>2</sup>

The value of  $C_i$  and  $C_o$  is different for different types of transitions. Values for some of the transitions are as follows (Table 5.4). The most practical values of  $C_i$  and  $C_o$  are 0.50 and 1.00 respectively.

**Table 5-4:  $C_i$  and  $C_o$  values for different transitions**

S. N	Type of transition	$C_i$	$C_o$
1	Culvert pipe terminates in headwall across channel	0.5	1.00
2	Headwall with rounded transition of which the radius exceeds 0.1 times the depth of water	0.25	0.50
3	Broken back transition with flare angle of about 1:5	0.20	0.40

### 5.4.2 Design of Piped Canal

Piped section may flow full or part full.

For piped canals flowing full, the capacity is determined by the:

- Pipe diameter (internal);
- Pipe length;
- Difference in water level between upstream and downstream (i.e. the head loss).

Pipes are designed for a velocity in the range of 1.0 to 3.0 m/s.

Pipe design charts are used to calculate the head loss due to friction within the pipe. Entry, exit and bend losses are added.

Total head loss ( $H_L$ ) is given by:

$$H_L = H_i + H_{fr} + H_b + H_o$$

Where,  $H_i$ ,  $H_o$  are entrance and exit head losses (m)

$H_{fr}$  is the friction head loss over the length of the pipe (m)

$H_b$  is the head loss in bends (m)



The entrance and exit losses are calculated using formula:

$$H_i = \frac{C_i(V_p^2 - V^2)}{2g}$$

$$H_o = \frac{C_o(V_p^2 - V^2)}{2g}$$

Most pipe entrances are abrupt and values of  $C_i = 0.5$  and  $C_o = 1.0$  are generally used. Friction losses may be calculated using the charts given in Figures 10.12 to 10.15 of Chapter 10.3, Rigid Boundary Canals from D2 Field Design Manual Vol I.

Losses in bends,  $H_b$ , are given by:

$$H_b = \frac{K_b(V_p^2)}{2g}$$

Where,  $K_b$  is the bend loss coefficient, taken as 0.10  
 $V_p$  is the velocity in pipe (m/s),  
 $g$  is the acceleration due to gravity (m/s<sup>2</sup>),

### 5.4.3 Design Examples of Piped Canal

Case-I: Pipe flowing full

Data:

Discharge = 100 l/s

Velocity = 0.5 m/s

Pipe type = HDP

Length = 70 m

2 bends at 45° , radius = 2\* diameter

Calculation:

From HDP pipe friction chart (Figure 10.15) from chapter 10.3 "Rigid Boundary Canals" D2 Field Design Manual Volume 1, select 250 mm diameter pipe then,

$V=Q/A= 0.1/0.049 = 2.05$  m/s, acceptable

Friction loss is 1.1 m/100 m

Over 70 m, head loss =  $70 \times 1.1/100 = 0.77$  m

Entry and exit losses =  $1.5 [2.05^2 - 0.5^2] / 19.62 = 0.32$  m

Pipe bend loss =  $0.09 \times 2.05^2 / 19.62 = 0.02$  m

For two bends, loss = 0.04 m

Therefore, total head loss =  $0.77 + 0.32 + 0.04 = 1.13$  m

Larger diameter pipes will generally flow part full. These cases are treated similarly to covered canals. The following table presents hydraulic properties of pipes flowing part full.

**Table 5-5: Hydraulic Properties of Pipes Flowing Part Full**

Water Depth From Invert	Wetted Area (A)	Wetted Perimeter (P)	Hydraulic Radius, (R)	Water Surface Width (Ws)
0.1d	0.04 d <sup>2</sup>	0.64d	0.063d	0.6000d
0.2d	0.11 d <sup>2</sup>	0.93d	0.118d	0.8000d
0.3d	0.20 d <sup>2</sup>	1.16d	0.172d	0.9165d
0.4d	0.29 d <sup>2</sup>	1.37d	0.212d	0.9798d
0.5d	0.39 d <sup>2</sup>	1.57d	0.250d	1.0000d
0.6d	0.49 d <sup>2</sup>	1.77d	0.277d	0.9798d
0.7d	0.58 d <sup>2</sup>	1.98d	0.293d	0.9165d
0.8d	0.67 d <sup>2</sup>	2.21d	0.303d	0.8000d

A check needs to be made on the hydraulics of the pipe to see whether the pipe will submerge or not. The Froude number in pipes flowing part full (and covered canals) should be kept below 0.55 to avoid standing waves. The Froude number is calculated from formula

$$F = [\alpha V^2 / (g \cdot d_m)]^{0.5}$$

Where,  $d_m$  = Flow area in sq m/Water surface width in m,

Case-II: Pipe flowing part full

Data:

Discharge = 200 l/s

Depth = 0.5 m

Pipe type = concrete

Length = 150 m

Velocity in canal = 0.5 m/s

Manning "n" = 0.015

Simple head wall for entrance/exit

Calculation:

Velocity is to be kept below 3.0 m/s

Pipe is to flow with minimum of 0.20 diameter freeboard.

From Table 5.5 Area for water depth of 0.8 diameter = 0.067d<sup>2</sup>

Estimate minimum pipe size within velocity limit

From continuity,  $A = Q/V_{max} = 0.2/3.0 = 0.067 \text{ m}^2$

Hence,  $0.67d^2 = 0.067$

And  $d = 0.315 \text{ m}$

Required diameter = 0.315 m

Use 350mm diameter pipe as next available size,

$V = Q/A = 0.2 / (0.67 \times d^2) = 0.2 / (0.67 \times 0.35^2) = 2.44 \text{ m/s}$

Before proceeding with the calculation of losses, check the pipe inlet setting in relation to the canal depth,

Canal depth = 0.5 m

Pipe diameter = 0.35 m

If pipe invert is set at canal bed level, then water depth above invert = 0.5 m. This is about 1.4 x diameters, i.e. the pipe may submerge (greater than 1.2 times pipe diameter).

To avoid submergence, the pipe invert would have to be set above canal bed level which is not satisfactory for sediment transport. Therefore, increase pipe diameter to 0.6 m (to match the canal depth) and set invert of pipe at bed level.

Set outlet to ensure that pipe is not submerged. Allow 0.2 x diameter freeboard i.e., set pipe invert at (downstream water level – 0.8 x diameter).

$$V = \frac{1}{n} R^{2/3} S^{1/2} \quad \text{or, } S = n^2 V^2 / R^{4/3}$$

For depth of flow = 0.8 x diameter (Table 5.5),

$$A = 0.67 d^2 \quad R = 0.303 d$$

$$A = 0.34 \text{ m}^2 \quad R = 0.182 \text{ m}$$

Therefore,  $V = 0.83 \text{ m/s}$

$$S = (0.015^2 \times 0.83^2) / (0.182^{4/3}) = 0.0015$$

$$\text{Head loss} = S \times \text{length} = 0.0015 \times 150 = 0.23 \text{ m}$$

Entry/exit losses for  $C_i = 0.5$ ,  $C_o = 1.0$

$$\begin{aligned} \text{Losses} &= [1.5(V_p^2 - V^2)] / 2g \\ &= [1.5(0.83^2 - 0.5^2)] / 19.62 \\ &= 0.03 \text{ m} \end{aligned}$$

$$\text{Total head loss} = 0.23 + 0.03 = 0.26 \text{ m}$$

## 6. Sediment Control Structures

### 6.1 Gravel Traps

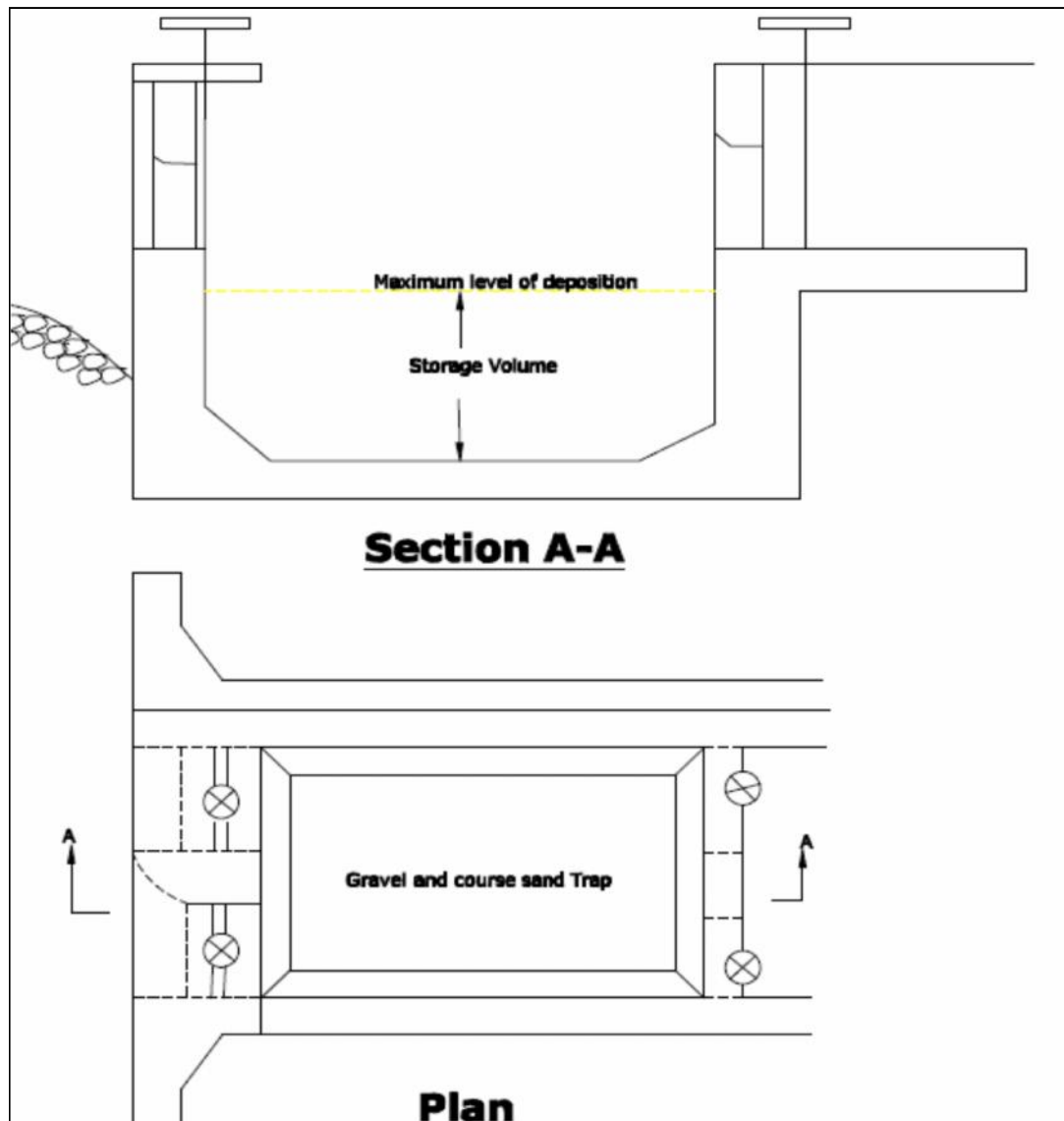
In small irrigation schemes in the hills a gravel trap behind the intake is provided to exclude the gravel from entering into the canal. The design of gravel traps differs from that of settling basins because the former handle coarse material which enters near the bed, rather than suspended material which has to be settled through the depth. The main design principle is that the water velocity through the basin should be less than that which is competent to move the smallest size of gravel. Table 6.1 gives nominal and design velocities for various particle sizes.

**Table 6-1: Flow velocity through Gravel Trap**

Particle Size mm	Nominal velocity (m/s) for Depths of		Design velocity (m/s) for Depths of	
	3 m	1.5 m	3 m	1.5 m
100	4.0	3.5	2.0	1.7
60	3.4	3.0	1.7	1.5
40	3.0	2.6	1.5	1.3
20	2.3	2.1	1.2	1.1
10	1.8	1.6	0.9	0.8
5	1.8	1.6	0.7	0.6
2	0.8	0.7	0.4	0.3

Gravel traps may be emptied by hand or by flushing. For small schemes, hydraulic flushing will not usually be appropriate; manual clearing is more likely to allow an economic design with more assured operation (Figure-6.1).

Figure 6-1: Typical Gravel Trap for Small Schemes

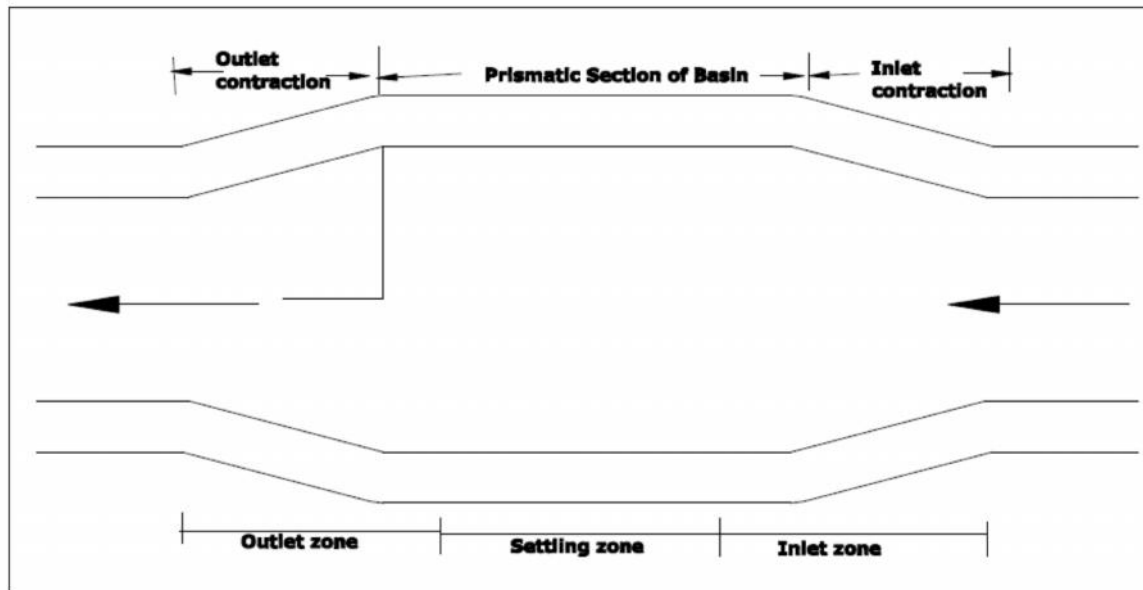


## 6.2 Sand Traps

### 6.2.1 General Configuration

Sand traps operate as settling basins and have three parts: inlet zone, settling zone and outlet zone (Figure-6.2). The design configuration of inlet zone affects the performance of sand traps. To achieve optimum hydraulic efficiency and effective use of the settling zone, the inlet needs to distribute inflow and suspended sediment uniformly over the cross-sectional area of the settling zone. The size of settling zone depends upon the capacity of canal and its location. The minimum length to width ratio ( $L/W$ ) is taken as 2 to 3.

**Figure 6-2: Typical Configuration of Sand Trap**



In irrigation systems, it is generally feasible to achieve a better L/W ratio, say 8 to 10. Basin shape can be improved by subdivision with longitudinal divide walls, which may also be desirable for operational reasons.

### **6.2.2 Sand Trap Design**

For small irrigation schemes where there is no data available for the design of sand trap a simplified method is adopted here.

- i. Assess the suspended solids concentration and their mean size

From general knowledge and site inspection assess the maximum suspended solids concentration and the probable D20 and D50 sizes. If flood flows can be totally excluded by closing the intake then provide the criterion for gate closure. Otherwise, a peak concentration at least as high as the maximum reached annually, should be assumed.

The design of a settling basin is very sensitive to the particle size of the sand to be trapped. Samples of the sediment entering an existing canal, or in the river at the intake site, should be collected and analyzed for particle size distribution. For design of the settling basin, the D20 particle size should be used (D20 size being that which 20% of the sample by weight is smaller than). It is not considered practical to provide a settling basin for D20 particle sizes less than 0.15 mm. For design of the scouring velocity in the settling basin, the D50 size should be used. If there is no available information, the following values can be used for design (Table-6.2).

- i. Assess transporting capacity of the canal

Consider the design of the canal in terms of its transporting capacity. For example, in a small existing canal assume a maximum capacity of 100 mg/l of 0.3 mm diameter sand during the month with the highest sediment load.

**Table 6-2: Recommended values of sediment particles**

Region	Maximum suspended solids concentration (mg/l)			D20 Size mm	D50 Size mm
	Poor Intake Site	Medium Intake Site	Good Intake Site		
Hills	2 000	1 500	1 000	0.2	0.4
Terai	2 000	1 500	1 000	0.15	0.3

- ii. Calculate the required trapping efficiency

The difference between (i) and (ii) gives the trapping efficiency required.

- iii. Calculate the required surface area of the settling basin

The design curves (PDSP Manual D2) for D20 particle size can be used to assess the settling basin area. These curves have been simplified to be appropriate for small schemes. Choose the basin length and width to give a length/width ratio of 6 to 10 (Figure 6.3).

- iv. Flow depth

Choose a flow depth sufficient to ensure no re-scour of deposits when there is full storage

- v. Storage requirements

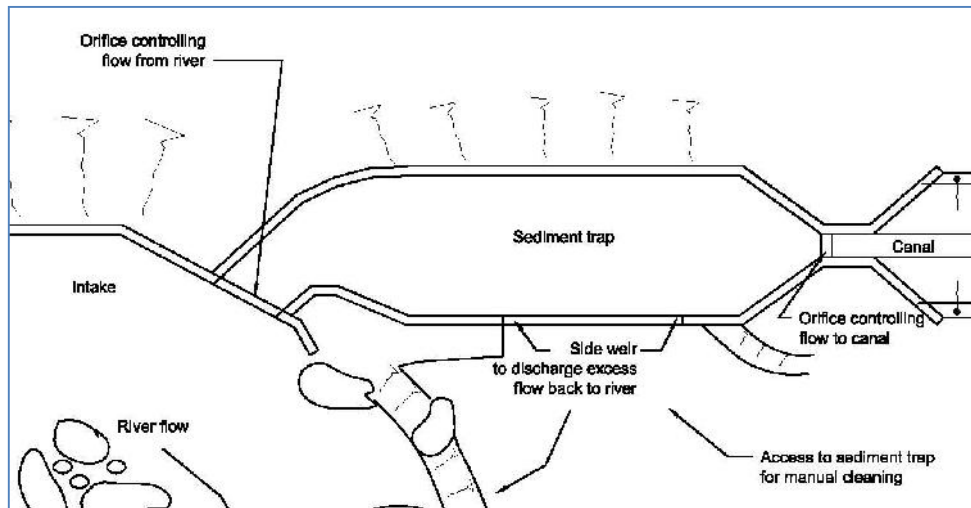
Consider storage requirements in terms of frequency of clearing out, and allow this volume below the nominal basin depth obtained in (v) above.

The storage volume,  $V_s$

$$V_s = \frac{Q \times X_{\max} \times y \times FI \times 3600 \times 24}{BD \times 10^6}$$

Where,  $Q$  is flow rate through settling basin in  $m^3/s$ ,  
 $X_{\max}$  is the maximum sediment concentration (by mass) of entering flow in  $mg/l$ ,  
 $y$  is the trap efficiency,  
 $BD$  is the bulk density of settled material in  $t/m^3$ ,  
 $FI$  is the interval between flushing or emptying in days,

**Figure 6-3: Typical Layout of Sediment Trap**



For small schemes:

$X_{max}$  can be obtained from (i) above

$Y$  can be taken as 0.90,

BD can be taken as 2.0 t/m<sup>3</sup>

FI can be taken as 7 days

- vi. Finalize the size, geometry and location, and check that it remains consistent with the assumption made in (iv)



## 7. Canal Structures

### 7.1 Head Regulator

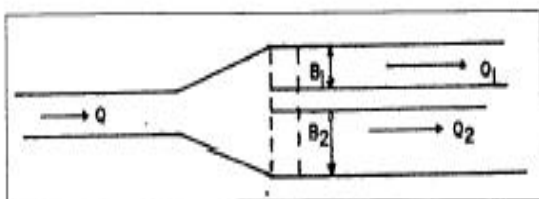
Head regulator controls the amount of water flowing into the off-taking canal. Head regulator is structured at the head of each canal taking water from the main canal. Head regulator is equipped with vertical sliding gates, Road Bridge, and flow measuring device depending upon the size of the canal, and type of the scheme. In small scale irrigation scheme head regulator may not have road bridge and flow measuring device.

### 7.2 Cross Regulator

Cross regulator heads up water level in the parent canal and allows diverting part of this water to the off-taking canals. Cross regulator is structured at the downstream of off-taking canal and is equipped with vertical sliding gates and road bridge for vehicular transport. In small scale irrigation schemes cross regulators are not necessary to construct.

### 7.3 Proportional Divider

Flow divider divides the incoming flow of the canal two into branching canals. Flow divider may be proportional divider or division box. Flow divider may be equipped with gates or has no gates. Most of FMIS in Nepal have proportional dividers with no gates. These proportional dividers divide water according to set norms and practices of the community. This practice leads to the rigid system of water distribution and farmers have no opportunities to take extra water. The system runs automatically with no need to open or close or adjust the flows.



**Figure 7-1: Definition Sketch and Photograph of Proportional Divider**

The width of the structure is proportional to the designed discharge of each off-taking canal which is visible clearly by the farmers. The downstream condition of the proportional divider should be of free flow condition in all off taking canals. In other words the downstream water level of the canal should not influence the flowing pattern of the proportional weir.

The design of proportional divider is concerned with the fixing of the width of the weir and provision of energy dissipating arrangement at the downstream of the off-taking canals. The width of the weir is calculated considering the broad crested weir:

$$Q = 1.71 B H^{3/2}$$

Where, B is the width of the weir, and H is the height of the crest; the width of the weir is proportional to the discharge in free flow condition.

The downstream energy dissipation is calculated as per the hydraulic jump calculations. For small scale structures the length of the basin is 5 to 6 times the height of the drop (difference in water levels of upstream and downstream canals).

## 7.4 Outlets

Outlets are the small structure used to supply the water from canals to the field. Depending upon the type, size and importance of the scheme outlets are of various types. The main design objective of these outlets is to supply irrigation water equitably up to the tail end of the schemes. In large irrigation systems outlets are both gated and un-gated. The choice of the gate depends upon the necessity of the operational flexibility. For small scale irrigation outlets are simple pipe outlets fixed at the head of the field channel. The control of water could be managed by manual inspection or letting to flow continuously. In hill schemes pipe outlets provide sufficient drop to the irrigated area which is considerably lower than the parent canal.

### 7.4.1 Design of Pipe Outlet

The design formula for a submerged orifice is:

$$Q = C A \sqrt{H}$$

The design formula for a free flow orifice is:

$$Q = C A \sqrt{H}$$

Where, Q is outlet discharge in lps,

A is the area of the pipe in m<sup>2</sup>

H is the head difference between parent canal water level and water level of outlet canal

C is coefficient and equals to 3,300 for pipe shorter than 6 m and 2,800 for pipe longer than 6 m (for submerged flow) & 2760 (for free flow)

Thus for a 100 mm diameter HDP pipe with a 0.25 m head difference, the discharge is:

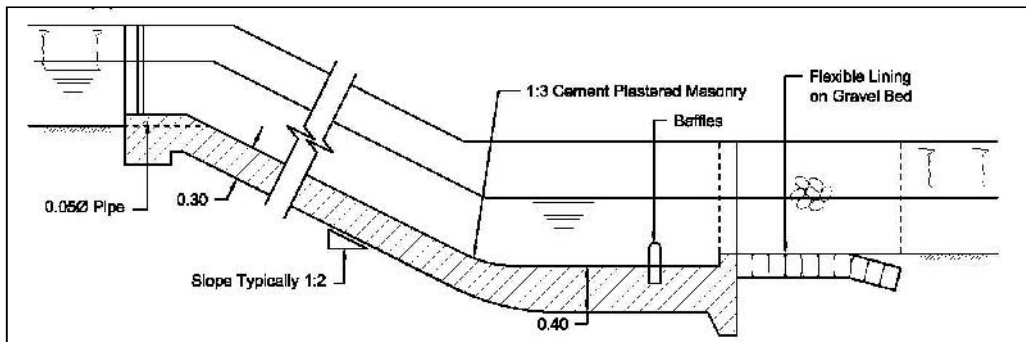
$$Q = 3300 \times 0.102 \times 0.250.5 = 13 \text{ l/s (for submerged flow)}$$

$$Q = 2760 \times 0.102 \times 0.250.5 = 11 \text{ l/s (for free flow)}$$

## 7.5 Drop Structures

In general drop structures are required in a canal when the gradient is steeper than that allowed by the tractive force. If drops are not provided, erosion will occur in the canal. In the hills, if the canal is in rock, quite steeply graded canals can be made with no need for bed protection, but some form of stilling basin should be cut in the rock at the end of the chute.

Figure 7-2: Definition Sketch of Chute Drop



For the small drops (up to 2.0 m), the straight drop fall is the simplest and most appropriate drop fall structure, for larger drops, various other options are possible:

- Chute
- Cascade
- Pipe drop

### **Design recommendation**

The common hydraulic principle in all types of drop structures is the dissipation of Excess energy as the water drops from a high level to a low level. All of the water's excess energy must be dissipate inside the drop structure before water is allowed back into the downstream canal. Small scale irrigation system in remote hills, construction of large drop structure is difficult and undesirable. Below 2 meters vertical or chute drops and below 4 meters cascade or pipe drops are more appropriate.

- In case of straight drop, drop should be preferably made in multiples of 0.5 m i.e. 0.50 m, 1.00 m, 1.50 m or 2.00 m.
- Except the pipe drops, the crest width/flume width/cascade width should be made approximately equal to the upstream canal bed
- Generally rectangular chute should be used for slopes of up to 1:2
- A cascade for slopes from 1:1 to 1:2, or a pipe drop for slopes steeper than 1:1 or for very long drops may be more appropriate
- In case of cascade drop, the drops should not exceed 1 m each and steps walls should be at least 0.50 m high
- In case of pipe drops, an inlet box with upstream overflow weir for safe disposal of excess flows and outlet stilling box are required. The maximum pipe velocity for HDPE pipes should be 2 m/sec
- The structures should be made out of 1:3 cement plastered masonry
- Pitching should be provided downstream of the structure

## **7.6 Escape Structure**

Escape structures are the safety structures for the release of excess water of the canal. In addition escape structures are provided for emergency release of canal water. Excess water can enter into the canal both in the dry and rainy seasons.

In small irrigation schemes overflow escapes are suitable in the hills while in the Terai gated escape structure may also be suitable depending upon topography and size of the canal. For remote canal alignment overflow type escapes are suitable and are located just upstream of the natural drainage channel. Gated escape structures need human intervention to adjust and control flow hence it is not recommended in the remote locations. Generally the interval of escape structure is based on the size of the canal and topography. In the hills it is recommended to provide escapes at an interval of 500 m whenever natural drainage channels are available.

### **Design Concept of overflow escape structure:**

- i. Overflow escapes are designed as side channel weir,

$$Q = 1.7 W h^{3/2}$$

Where, Q is the flow across the crest (m<sup>3</sup>/s),  
W is the crest width (m), and  
h is the water depth across the crest (m)

- ii. The crest level is set 0.05 m to 0.10 m above design water level of the canal,

- iii. The head over the crest should not exceed 50% of the freeboard,
- iv. The length of the crest is calculated for 50% of the canal discharge or estimated excess discharge,

For small irrigation scheme escapes are overtopping sections of the canal at the location where escaped water can channelize to the natural drainage channel. Over topping sections are provided at the upstream of the Superpassages or at the center of the aqueducts.

## 7.7 Bridges and Culverts

Bridges and culverts are required to carry foot, vehicular and animal traffic across the canals. If crossings are not provided, the canal bank will be rapidly eroded, causing local instability to the canal. Crossing should be provided where all the major paths, roads and tracks cross the canal alignment. The culverts may be concrete pipe culvert and box culvert. The bridges may be foot bridges, large bridges, and walkways. The choice of pipe culvert or box culvert depends upon the size of the canal and its importance for vehicular movement.

The pipe culverts are designed to flow full and have the fall of 0.05 m in normal condition. The design head loss through the culvert for preliminary assessment is taken between 0.05 m to 0.10 m. For the detail assessment of the head loss is carried out with the consideration of friction loss in the pipe, and inlet and outlet loss at upstream and downstream of the pipe.

$$h_i = 1.5V^2 / 2g$$

Where,  $h_i$  is the inlet and outlet loss in m, and V is the velocity of flow in m/s;

For pipe culverts flowing free with 0.10 m nominal free board and 0.05 m head loss the size of pipes and capacities are recommended as follows (Table 7.1).

**Table 7-1: Capacities of Free Flowing Pipe Culverts**

Pipe No	Diameter of Pipe (m)	Discharge (l/s)	Remarks
1	0.45	100	
1	0.60	200	
1	0.75	300	
1	0.90	450	
1	1.20	900	

*Source: PDSP Manual, 1990*

The flow velocity is recommended to limit within 1 m/s in order to minimize the downstream scour and protection works therein. In Nepal two categories of concrete pipes of standard sizes are available for the purpose pipe culverts: NP2 and NP3. Generally, NP2 pipes are used for road works while NP3 pipes are used for irrigation works. The detailed characteristics of standard concrete pipes is found in IS Code 458:2003.

## 7.8 Retaining Wall

### 7.8.1 General

Retaining walls are the structures necessary along the canal alignment to protect the canal from slipping or sliding. In general retaining walls are necessary in hill irrigation schemes where canal alignment is not stable enough. Based on the materials used retaining walls are categorized as follows:

- Masonry retaining wall
- Masonry with dry stone panels
- Dry stone walls
- Concrete retaining walls
- Gabion walls

### 7.8.2 Design Concept of Dry and Gabion Retaining Wall

The design of retaining wall involves the fixation of bottom width, top width, height and material to be used. For dry stone and gabion retaining walls the design criteria is as follows:

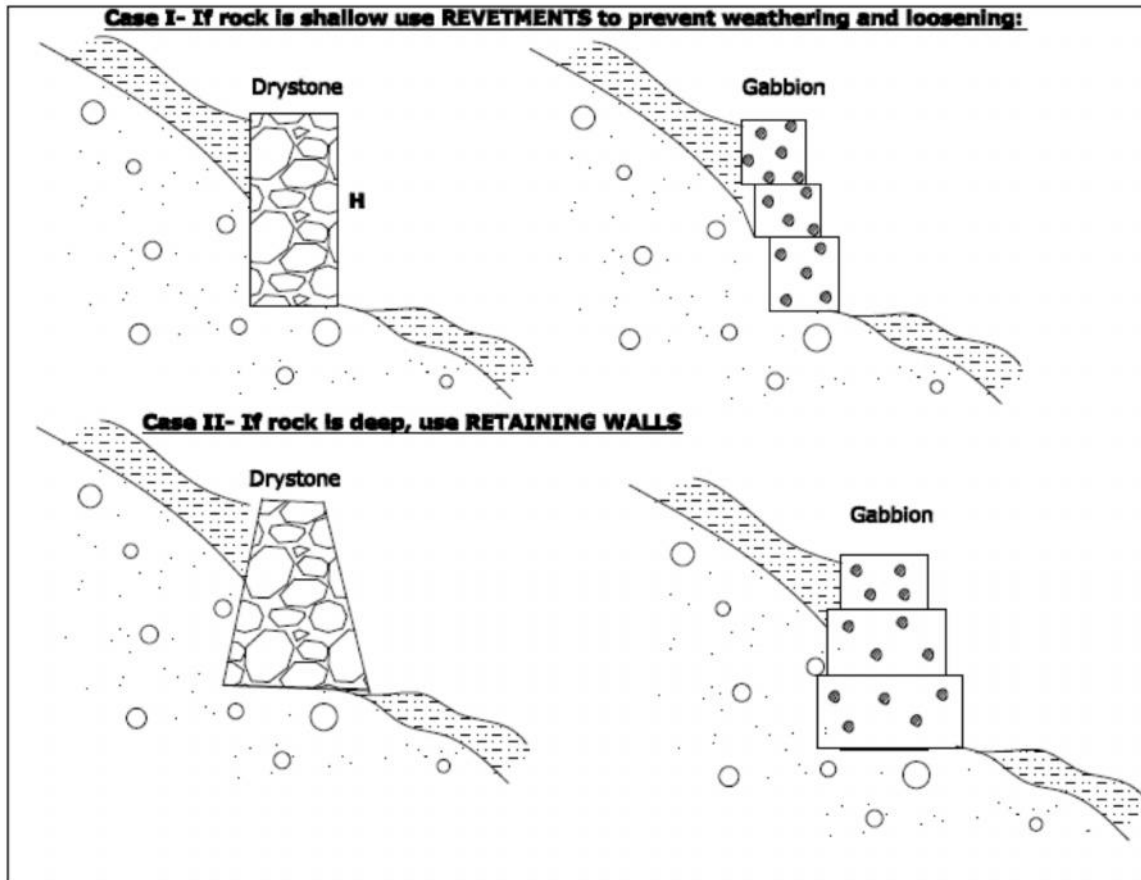
- i. For shallow depth slide
  - a. Dry stone wall with vertical face  
Max depth of wall (H) = 4 m,  
Thickness of wall (W) > 0.2 H,  
Face angle 4:1
  - b. Gabion wall with stepping face  
Max depth of wall (H) = 6 m,  
Thickness of wall (W) > 0.2 H,  
Face angle 4:1
- ii. For deep depth slide
  - a. Dry stone wall with sloping face  
Max depth of wall (H) = 4 m,  
Top thickness of wall (W) > 0.25 H,  
Base thickness of wall (B) > 0.70 H
  - b. Gabion wall with stepping face  
Max depth of wall (H) = 6 m,  
Top thickness of wall (W) > 2 m,  
Base thickness of wall (B) > 0.70 H

### 7.8.3 Design Procedure of Masonry and Concrete Retaining Wall

The size of the retaining wall for masonry, concrete and RCC is fixed on the basis of stability calculation which is checked against overturning and sliding. The design procedure involves the following steps:

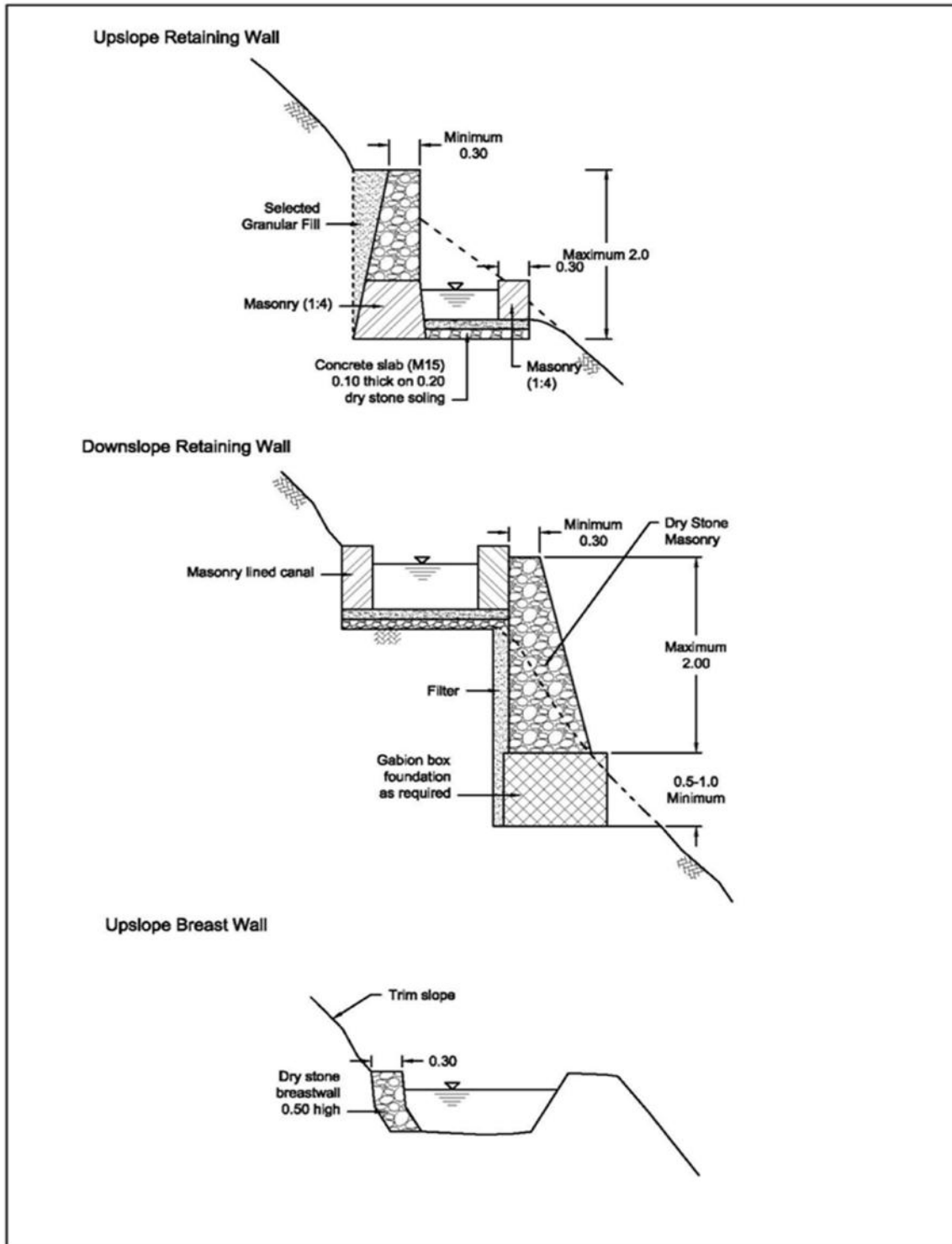
- i. Assess the factor of safety
  - Factor of safety against overturning  
2.0 for normal loading case,  
1.50 for extreme loading case
  - Factor of safety against sliding  
1.5 for normal loading case,  
1.2 for extreme loading case,

Figure 7-3: Definition Sketch of different type Retaining Walls



- ii. Calculate the loads acting on the wall
  - active soil pressure due to horizontal ground,
  - surcharge load of the soil behind the wall,
  - hydrostatic pressure behind the wall,
  - self weight of the wall,
- iii. Assess the allowable stress (compressive and tensile) of the wall based on the material of the wall.
- iv. Assess the filter materials to be used behind the wall section
- v. Draw the load diagram
- vi. Calculate the forces and moments on the toe of the wall
- vii. Check the factor of safety
- viii. Calculate the bearing pressure and check against allowable pressure
- ix. Check the stress at the junction of the wall

Figure 7-6: Possible Retaining Examples in Canals



## 8. Cross Drainage Structures

### 8.1 Type of Cross-Drainage Structure

There are five types of cross drainage structures in irrigation canal alignments:

- Aqueduct- when canal passes over the drain,
- Superpassage- when canal passes under the drain,
- Siphon- when canal passes under the drain,
- Drain culvert- when drain passes under the canal, and
- Level crossing-when canal crosses the drain at the same level

### 8.2 Design Considerations

#### 8.2.1 Design Discharge

The design flood discharge is assessed by hydrological analysis as described in Chapter-3. In small cross drainage structures the flood return period may be considered as 5 to 10 years. For aqueduct 10 years return period may be essential while for Superpassage, siphon, and culvert 5 years return period may be adequate.

#### 8.2.2 Waterway of the Drain

The waterway of the drainage is necessary to fix for the structure in order to avoid constriction of the flood flow. In the hills and mountain areas the waterway is provided within the existing defined banks of the river or drain. In Terai area Lacey's waterway may be appropriate;  $P=4.75\sqrt{Q}$  where, Q is the design flood discharge of the drain.

#### 8.2.3 Contraction and Expansion of Waterway

The contraction and expansion of the waterway of the drainage channel should be smooth in order to minimize loss of head therein. The contraction should not exceed 20% for drains. The transitions of the aqueduct, siphon, and culvert barrel should not be steeper 2:1 in contraction and 3:1 in expansion. The transitions are designed on the basis of Mitra's hyperbolic transition equation:

$$B_x = \frac{B_n \times B_f \times L_f}{L_f \times B_n - X(B_n - B_f)}$$

Where,  $B_x$  is the bed width at any distance x from the flumed section,  
 $B_n$  is the bed width of normal canal section,  
 $B_f$  is the bed width of flumed canal section,  
 $L_f$  is the length of transition,

#### 8.2.4 Head Loss through Structure

The loss of head across the structure also governs the choice of structure. Adequate hydraulic head drives the canal flow across the drainage structure. Aqueducts and Superpassage have less head loss while siphon requires higher head difference between its inlet and outlet. The velocity through the barrel of the siphon or in the flume section of the aqueduct is limited to 2 to 3 m/s.



### 8.3 Design Concept of Aqueduct

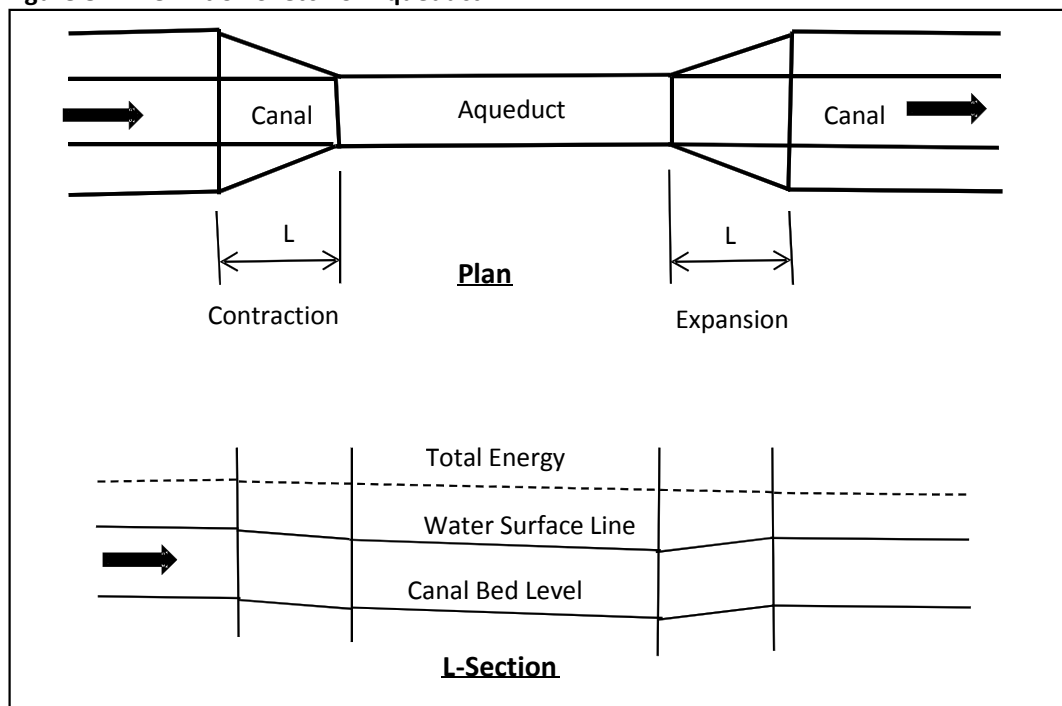
Aqueducts are used where canal crosses over deeply incised streams or drains. The basic considerations in the design of aqueduct are:

- HFL of drain or stream should be sufficiently below the bed level of the canal;
- Banks of the drain should be stable;
- For small irrigation schemes the span of aqueduct should limit to 10 m;
- Water velocities in the flume should be from 1.0 to 1.5 m/s;

Figure 8-1: Aqueduct in Hills



Figure 8-2: Definition Sketch of Aqueduct



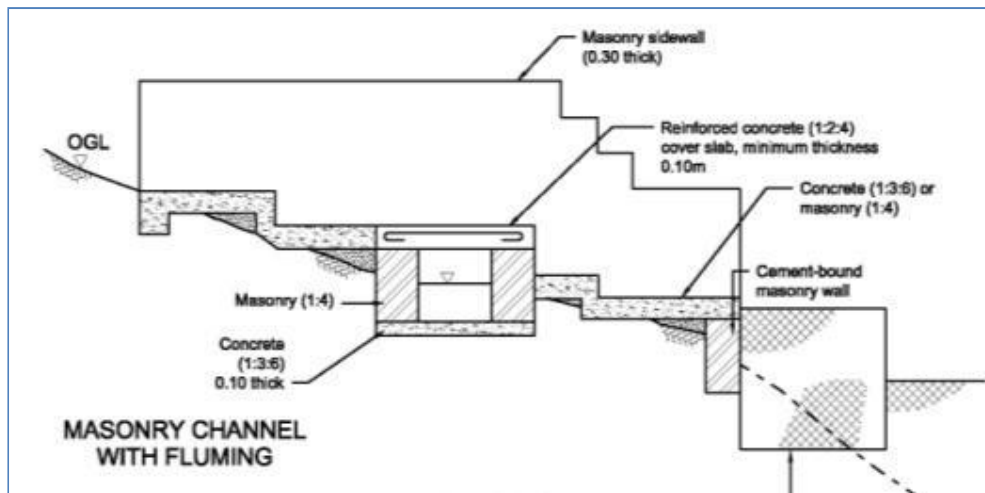
## 8.4 Design Concept of Superpassage

There are many types of Superpassage based on their materials of construction, size of the drainage channel, and need of protection works. The design of each type of Superpassage depends solely on the topographical conditions and nature of drainage channel. According to the materials of construction Superpassage may be:

- Stone masonry;
- Concrete pipe; and
- Reinforced concrete

In most small irrigation schemes Superpassages are like a covered canal with guide walls to confine the drainage flow. However, downstream protection works are essential in several instances to dissipate the excess energy of the drainage channel during the flood. A typical sketch of the Superpassage is presented hereunder (Figure-8.3).

**Figure 8-2: Typical Superpassage with u/s guide walls and d/s protections.**



## 8.5 Design Concept of Canal Siphon

Inverted siphons are used to cross the drainage channel by a canal. There are two types of siphons:

- Shallow siphon to cross shallow and wide river with little pressure head, and
- Deep siphon to cross deep river

**Shallow siphon:** Shallow siphons are designed so that the river or drain is kept on the same gradient and the canal flows in a conduit under the river bed. Small siphons are often designed using concrete pipes in a masonry or concrete surround. Adequate velocity should be provided to prevent siltation at low flows. For small irrigation canals drop type inlet can also be provided. To prevent choking from floating debris trash rack is provided at the upstream of inverted siphon.

**Deep Siphon:** Deep siphons are used in the hill schemes to cross the river in deep valleys. The siphon is taken down the valley side, anchored by blocks, and then crosses the river on the short span bridge. Due to high pressures the siphons are usually made of steel pipe (Figure 8.4). In some cases bridge is in suspension with pipe held in wire slings below the cable.

## 8.6 Design Concept of HDP Pipe Crossing

The design of HDP pipe consists of three components:

- Hydraulic design of HDP pipe; and
- Structural design of cable suspension

Hydraulic Design of HDP Pipe: Pipe crossing section may flow full or part full. Considering the full flow of the section the following parameters need to be decided first:

- Diameter of pipe (internal) based on design discharge of the canal system;
- Length of pipe based on the topography of the drainage section;
- The difference in water level between upstream and downstream or inlet and outlet.

The limiting velocity of the HDP pipe is considered less than 3 m/s. Based on this limiting velocity, and design discharge, the diameter of the pipe and required loss of head therein is assessed from the pipe flow characteristics available in standard table (standard provided by the manufacturing company).

In addition to the loss of head in pipe friction other losses such as trash loss, entry and exit loss and bend loss need also be assessed by using standard formula and practices.

Entry and exit loss is assessed as,  $H_e = 1.5 \cdot (V_{\text{pipe}}^2 - V_{\text{canal}}^2) / 2g$

Where,  $V_{\text{pipe}}$  is velocity of water in pipe in m/s

$V_{\text{canal}}$  is velocity of canal at the inlet in m/s

Joint loss is assessed as 25% of friction loss for each joint. The bend loss is calculated as

$$H_b = C_b \cdot V_{\text{pipe}}^2 / 2g,$$

Where,  $C_b$  is bend coefficient,

$V_{\text{pipe}}$  is velocity of water in pipe in m/s

The trash rack loss is taken as 0.10 for small irrigation schemes.

**Structural Design of Cable:** The design of suspension cable consists of the calculation of saddle difference, cable inclination, tension in cable, and loads due to cable, pipe, wind load and other loads.

- Maximum permissible height difference between two saddles ( $h$ ) =  $E_h - E_l$ , where  $E_h$  and  $E_l$  are the elevation of higher and lower saddle (crossing).  $H$  is considered as  $S/20$  to  $S/25$  where  $S$  is clear span of the saddle or crossing;
- Cable inclinations at higher saddle ( $\beta_1$ ) =  $\tan^{-1} (4b + h) / l$  (degree) and cable inclinations at lower saddle ( $\beta_2$ ) =  $\tan^{-1} (4b - h) / l$  (degree), where  $b$  is the sag measured at the midpoint of the cable (m); and maximum cable inclination at saddle of higher elevation is given by,  $\beta_{\text{max}} = \tan^{-1} (4l/22 + l/25) / l = \tan^{-1} (0.1818l + 0.04l) / l = \tan^{-1} 0.2218 = 12.51^\circ$ , say  $13^\circ$
- Horizontal distance from the saddle of higher elevation to the lowest point of cable is given by;  $e = l/2(1+h/4b)$
- Max<sup>m</sup> sag at the lowest of cable from the saddle at higher elevation is given by  $f_{\text{max}} = b + h/2 + h^2/16b$
- Total horizontal tension (all cable) (HT) =  $G \cdot l^2 / 8b$ , where  $G$  is load in KN/m
- Total Max<sup>m</sup> tension (all cable) at the higher saddle is given by,  $T_{\text{max}} = H_T / \cos \beta_1 = H_T \cdot (1 + \tan^2 \beta_1)^{1/2}$
- Max tension in main cable (T(M) max) =  $T_{\text{max}} \cdot A_m / (A_m + A_h)$  and Max tension in hand rail cable (T(H) max) =  $T_{\text{max}} \cdot A_h / (A_m + A_h)$ , Where  $A_m$  and  $A_h$  are cross sectional areas of main and handrail cables respectively,
- To a close approximation when two saddles are at different elevations the arc length of the

loaded cable across the span is given by,

$L = l [1 + 2/3 * (f_{min}/l)^2 * (1+K)/K + 2/3 * \{(f_{min}+h)/l\}^2 * (1+K)]$ , where L is the total arc length i.e. cable length across the span to a very close approximation,  $K = \{l/(l+h)\}^{1/2}$ , l = span of crossing, and  $f_{min}$  is the lowest point of the cable from the elevation of saddle on the lower side under dead load case.

Trial and error procedure is adopted to solve these cable equations. The level span equations come close to give solutions for the inclined span when  $f_{min}$  is replaced by  $(f_{min}+h/2)$ . Since the equations for the level span are simpler than for inclined span, they can be used frequently for making the first guess for values to use in calculations with the inclined span equations.

For level span,  $E_h - E_l = h = 0$ ,  $C = 1$  and  $f_{min} = B_d = \text{dead load sag}$ , then the equation reduces to  $L = l [1 + 8/3 * (B_d/l)^2]$

- For span up to 80 m, Sag to Span ratio in dead load case = 20
- For span over 80 m, Sag to Span ratio in dead load case = 22
- Free board =  $F_b = E_l - HF_1 - f_{min}$ , where  $E_l$  = Saddle elevation of the walkway cable on the lower side,  $HF_1$  = highest flood level, however,  $F_b \geq 5\text{m}$
- Factor of safety for the cable =  $T_{break}/T_{max} \geq 3$
- Where  $T_{break}$  = Minimum breaking load for cables and  $T_{max}$  = Total cable tension at higher foundation level (all cables) KN
- Live load =  $400 \text{ kg/m}^2$  ( $4 \text{ KN/m}^2$ ) for span  $\leq 50\text{m}$
- Wind load =  $100$  to  $150 \text{ kg/m}^2$
- Dead load = Weight of all accessories
- Other load are effect due to temperature, snow load etc included in live load
- Cutting length of cable =  $1.1 * \text{Span} + \text{back stay length}$ , where back stay length is the cable length between saddle center and center of dead man or drum (anchorage block) as per foundation consideration.

The cross sectional area of the cable is the actual area of the wire without counting the void space between wires. The value for the area can be estimated from the information on the cable weight and specific gravity ( $7.843 \text{ t/m}^3$ ) for steel in the wire. The designer should obtain values of E (modulus of elasticity) and cross-sectional area from manufacturer or designer's best judgment has to be used.

**Figure 8-4: HDP Pipe Crossing**



## 8.7 Design Example of HDP Pipe Crossing

Design data:

Discharge to be passed through the pipe = 0.05 m<sup>3</sup>/s

Span of crossing = 20.0 m

Level difference between the pipe inlet and outlet = 2.0 m

Total length of HDP pipe required from inlet point to outlet point = 50.0 m

Velocity of flow in open channel near the inlet point of HDP pipe = 0.75 m/s

Max<sup>m</sup> allowable velocity in pipe < 3 m/s

Design steps:

We know,  $Q = V \cdot A$ ,  $A = Q/V$ ,

From standard Table for  $Q = 0.05$  m<sup>3</sup>/s, head loss =  $H_L$  (m/100m) = 0.88/100 = 0.0088 m, and

$V = 1.59$  m/s

Flow area of pipe,  $A = Q/V = 0.05/1.59 = 0.03145$  m<sup>2</sup>

Internal diameter of pipe,  $\phi = (4 \cdot A / 3.14)^{1/2} = (4 \cdot 0.03145 / 3.14)^{1/2} = 0.200$  m

Chose 225 mm outer diameter HDP pipe from series III (data from HDP pipe factory)

Available internal diameter of pipe = 225 - 2 \* 12.2 = 200.6 mm, which is close to chosen  $\phi = 200$  mm

Hence, OK

Calculation of losses

Headloss due to friction in 50.0 m long pipe =  $50 \cdot H_L$

=  $50 \cdot 0.0088 = 0.44$  m

Entry and exit loss =  $1.5 \cdot (V_{\text{pipe}}^2 - V_{\text{canal}}^2) / 2g$

=  $1.5 \cdot (1.59^2 - 0.75^2) / 2 \cdot 9.81 = 0.15$  m

Trash rack loss = 0.10 m

Joint loss is estimated as the friction loss in pipe length equivalent to 0.25 m per joint  
=  $0.25 \cdot (50 \text{ m} / 5 - 1) = 3.125$  m (considering length of one pipe to be 5 m)

Hence joint loss =  $0.0088 \cdot 3.125 = 0.0275$  m

Bend loss =  $C_b \cdot V_{\text{pipe}}^2 / 2g$ , where ( $C_b = 0.10$ )

=  $0.10 \cdot 1.59^2 / 2 \cdot 9.81 = 0.0123$  m per bend

Assuming max 4 bends in this case we get, bend loss =  $0.0123 \cdot 4 = 0.052$  m

Total loss =  $0.44 + 0.15 + 0.10 + 0.0275 + 0.052 = 0.77$  m < 2 m (level difference between inlet and outlet),

Hence, OK

## 9. Shallow Tube Well Irrigation

### 9.1 Groundwater Potential in Nepal

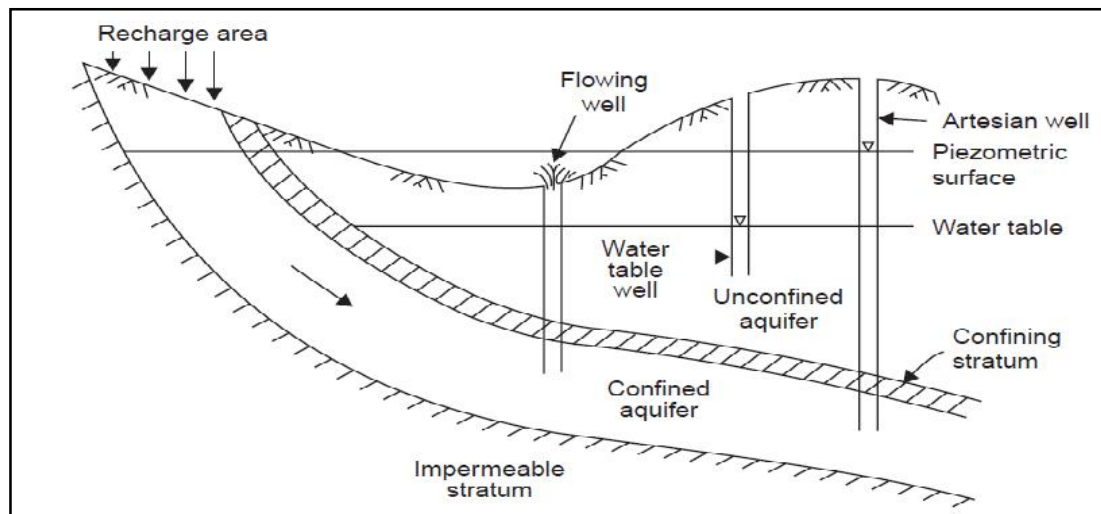
Groundwater is a part of hydrologic cycle and considered as reservoir of fresh water. Use of underground water for human needs is being practiced since time immemorial. There are abundant groundwater resources in Nepal Terai both in the form of shallow and deep groundwater. Shallow groundwater is extracted from the unconfined aquifer whereas deep groundwater is extracted from the confined aquifer of the ground.

The groundwater investigation was initiated in Nepal from 1959 under Groundwater Resources of Kathmandu Valley Investigation by Geological Survey of India. Later in 1969 a comprehensive investigation was started under USAID assistance mainly focusing Terai districts: Nawalparasi, Rupandehi, Kapilvastu, Banke, Bardiya, Kailali and Kanchanpur. In 1982 D.Duba had evaluated the groundwater potential of Nepal Terai as 11.60 Billion Cubic Meters (BCM). In 1987 Groundwater Development Consultant (GDC) had estimated the total potential of 10.75 BCM. In 1993 JICA had also carried out groundwater study in Nepal Terai mainly focusing on Jhapa, Siraha and Banke districts. Water Resources Strategy 2002 has prepared hydro-geological mapping (Figure-9.3) of the country and has assessed the rechargeable groundwater potential between 5.80BCM to 11.50 BCM.

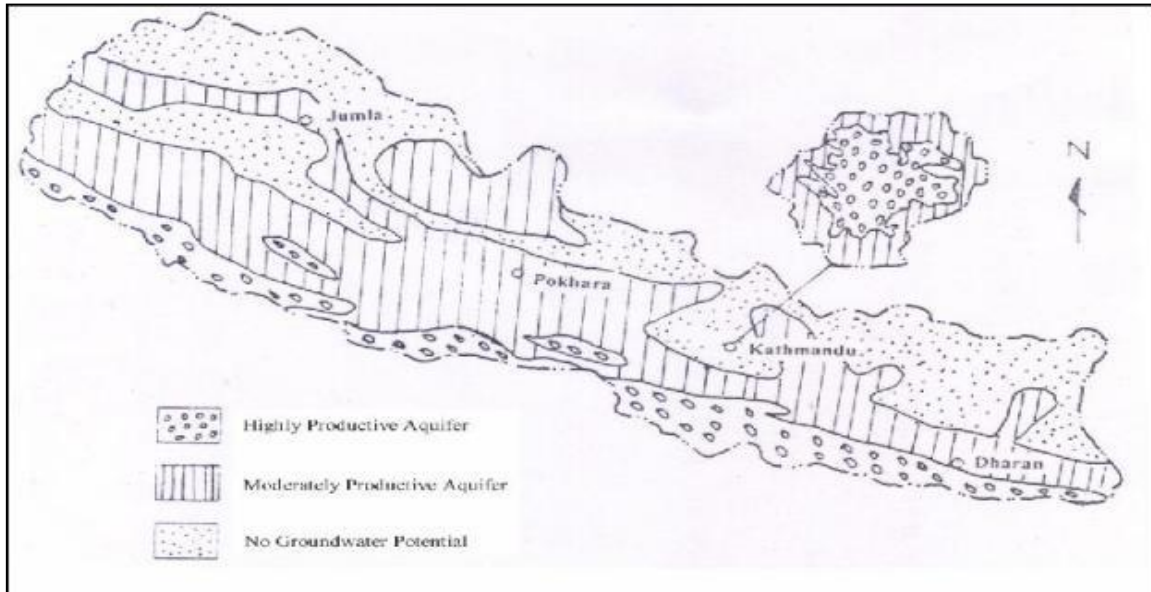


Figure 9-1: Typical Shallow Tubewell

Figure 9-2: Sketch of Groundwater Aquifers



**Figure 9-3: Hydro-geological Map of Nepal**



Source: WRS, 2002

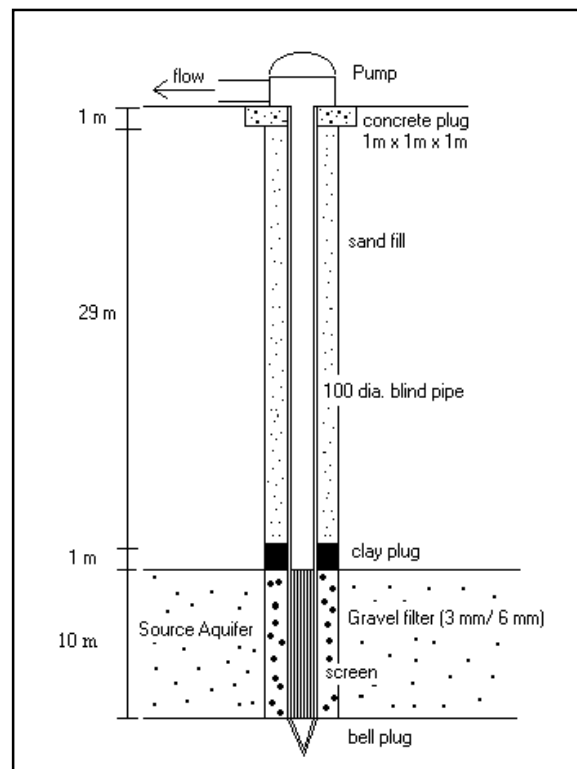
Based on the potential groundwater the irrigable area for shallow tube well in Terai comes to about 1.53 million ha. APP had targeted the installation of 176,000 numbers of STW in Terai each irrigating 2.50 ha of land. The present use of groundwater for irrigation is less 20 percent of its minimum potential.

## 9.2 Design concept

The design of shallow tube well involves the siting of the well, design of well, selection and design of distribution system, selection of appropriate pumps, and cost estimate of the shallow tube well construction. The site for tube well construction depends upon the groundwater potential, land suitability for irrigation, and type of well drilling technology. The design of tube well relates with the design of screen length, casing and gravel pack arrangements during drilling. The selection of water distribution system depends whether the piped system or channel system would be suitable for the given condition.

In the design of tube well two assumptions need to be made:

- Well yield, and
- Crop water requirement



**Figure 9-4: Typical Shallow Tubewell**

Based on the previous experience of similar wells in the locality, yield of the well needs to be assessed. The yield of the well is simply the expected discharge of the proposed well. It depends upon the hydro-geological strata of the well location, draw down of water table, length of screen to be provided and size of well boring. The discharge formula of the shallow tube is expressed as:

$$Q = \frac{f K (H^2 - h^2)}{2.3 \log_{10} R / r_w}$$

Where, Q- discharge in m<sup>3</sup>/s,  
 K-coefficient of permeability in m/s,  
 H- initial head existing before pump in m,  
 h-operative length of strainer in m,  
 R- radius of influence in m, and  
 r-radius of well in m

In practice the yield of the well is assessed to be 5 to 15 lps depending upon the hydrogeology of the area.

### 9.3 Suggested Design Criteria

Based on hydro-geological evidence and existing practice of shallow tube well construction GDC has suggested following design criteria for effective design and implementation.

- Minimum screen length of 10 m,
- Internal diameter of well 4 inch or 100 mm for 15 lps target yield or less,
- Minimum 12 m blank pipe from ground level to the top of the screen,
- Well development until water is clear,

### 9.4 Design Procedure of STW

Data required:

- Topographical maps,
- Cadastral maps,
- Soil infiltration test results,
- Drilling results (log sheets),
- Type of distribution system and
- Power source for pump

Design Steps:

- Assessment of hydro-geology of the area and suitability of STW development including quantity and quality of water;
- Assessment of well yield;
- Determination of well parameters such as screen type, screen length, and length of casing;
- Assessment of land suitability for STW irrigation;
- Design of cropping patterns with and without project conditions;
- Calculation of crop water requirement based on proposed cropping pattern,
- Preparation of distribution layout based on topography.
- Siting of well and access to the field;
- Selection of power supply options or availability of electric supply;
- Selection of type and technology of distribution system such as lined canal versus unlined canal, open channel versus piped channel;
- Design of channel size or pipe size;



- Selection of standard control, distribution, and outlet structures;
- Decide STW operating rules;
- Cost estimation;
- Cost benefit analysis;

## 9.5 STW Design Example

### 9.5.1 Design Data

Proposed irrigated area: 180 ha  
 Location: Mainapokhar, Bardiya  
 Hydro-geology: As shown in sketch (Figure-9.5)

### 9.5.2 Assumptions Made

Based on the hydrogeology of the area and past experience assume the discharging capacity of the STW is 5 lps, which will be sufficient to irrigate about 3 ha of land. The water requirement hence is assumed as 1.66 lps/ha.

### 9.5.3 STW Planning

The entire study area consists of 180 ha of land suitable for STW irrigation development. It is proposed to have 60 units of STWs each irrigating 3 ha of land with discharging capacity of about 5 lit/sec. The whole command area is developed in 2 clusters having 30 units of STW in each. The irrigated area of each cluster would be then 90 ha.

### 9.5.4 Tube-well Design

A typical shallow tube-well consists of a length of the well string continuous through aquifer. The productive aquifers are screened so that water can enter the well and other strata are sealed with blank casing. A gravel pack around the well string is necessary to prevent fine sand from the aquifer entering the well through the screen.

Diameter of pipe: 100 mm

Diameter of casing: 100 mm

Maximum possible depth of tube well: 25 m from ground level

The length of screen is calculated using formula:

$$L = \frac{A}{\text{Opening \%} * f * d}$$

Where, L – length of screen in m,

A - area of screen required in m<sup>2</sup>

A = discharge/entry velocity

Discharge is 5 lps and entry velocity is taken as 3 cm per sec

$$A = 5 * 0.001 / 3 * 0.01 = 0.166 \text{ m}^2$$

Opening percent is assumed to be 11 percent

d- screen diameter in m = 10 cm = 0.10 m

Thus, the length of screen is 4.83 m and takes as 5.0 m

The transmissivity of groundwater aquifer is assumed to be 1,100 m<sup>2</sup> per day for more than 60-m thickness aquifers, which gives the hydraulic conductivity of 18.33 meter per day. The design discharge of STW for irrigation of 3 ha of land is assumed to be 5 lps (432 m<sup>3</sup> per day). Drawdown is estimated from Logan's equation.

$$S = 1.32 \left( \frac{Q}{K \times L} \right)$$

Where, S - drawn down in m  
 Q – design discharge in m<sup>3</sup>/day = 5 lps = 432 m<sup>3</sup> per day  
 K – hydraulic conductivity in m per day = 18.33 m/day  
 L – length of screen in m = 5 m  
 Thus, drawdown S is equal to 6.22 m

### 9.5.5 Pump and Motor Design

The pump and motor design is carried out considering the critical condition of pumping the water from STW. When maximum suction head approaches to the permissible value the situation is critical. This maximum suction head includes drawn down in water level including losses in the non-return valve, bends and the pump mechanism. Based on the head to be required the capacity of pump is calculated.

$$P = (0.746 \times Q \times H) / (270 \times E)$$

Where, P = the required capacity of the pump in kW  
 Q = required design discharge of the STW in m<sup>3</sup>/hr = 18 m<sup>3</sup>/hr (5 lps)  
 H = total dynamic head in meters = head loss in delivery + draw down + depth to water table + other losses = 2.5 m + 6.22 m + 4.5 m + 1 m = 14.22 m, say 15 m.  
 E = pump efficiency usually taken for overall efficiency as 70 percent  
 $P = (0.746 \times 18 \times 15) / (270 \times 0.70)$   
 Thus P = 1.06 kW

Considering the factor of safety as 25 percent the pump motor capacity comes to:

$$\begin{aligned} \text{Capacity of the motor} &= 1.06 \times 1.25 \\ &= 1.33 \text{ kW or approximately 2 HP} \end{aligned}$$

Indian and Chinese pumps having 2 HP capacities are available in the market. In addition, there are submersible pumps for 4-inch diameter STW having 3-inch outlet delivery pipe. The discharge of this type of pump ranges up to 10 lps and 15 lps. Such new technology pumps are also available in the market.

### 9.5.6 Distribution System

The distribution system proposed is in line with the practice followed by the farmers. It is considered that a temporary thatch house will be made as a pump house and the distribution system will be of earthen channel. The length of such distribution earthen channel will be based on the specific field conditions depending on topography and its relief. In general the length of the distribution system will not exceed 240 m and its configuration will depend upon the actual site condition. The bed width of the canal will be about 20 cm with depth not more than 20 cm in trapezoidal shape.

## **10. Micro Irrigation**

### **10.1 Introduction**

Micro Irrigation, in the context of Nepal, is related to the alternate methods of both irrigation application and water acquisition. This chapter deals with the concept and design of various forms of micro irrigation feasible for Nepal.

### **10.2 Pond Irrigation**

#### **10.2.1 Design Concept**

The design of pond irrigation involves the design and assessment of the following components:

- Water availability assessment for the proposed site of pond;
- Irrigation water requirement assessment-based on cropping pattern, irrigation methods;
- Design of intake and conveyance canal or piped system-collection chamber, washout chamber, flow regulating chamber;
- Design of pond capacity or water storage reservoir; and
- Water application methods- drip irrigation, sprinkle irrigation and or free flooding method;

**Figure 110-1: Definition Sketch of pond**



Pond irrigation scheme shall be proposed in the water scarce area. In other words it shall be proposed where the source of water for conventional irrigation may not be sufficient. In such schemes the source of water may be quite small and need to be tapped carefully. The design of water intake shall involve the design of spring intake structure as adopted in drinking water supply schemes:

- Measurement of discharge with bucket and watch method,
- Design of overflow weir,
- Design of inlet chamber, and
- Sizing of conveyance pipe

The capacity of pond shall be fixed on the basis of the following:

- Available water at the source,
- Water requirement per day for the proposed crops, and
- Agreed pond operation rules with the farmers

The pond size shall be designed for the dry season water availability and shall be filled within 24 hours. LILI/HELVETAS has developed standards for the design and implementation of irrigation ponds. The design standard of the ponds as prescribed by LILI/HELVETAS is as follows:

- Minimum water requirement at source: 300 liter per ropani per day,
- Average irrigation water demand: 500 liter per ropani per day,
- Peak demand: three times of the average demand,
- Irrigated area to be covered by a single pond: maximum 40 ropani and minimum 10 ropani,
- Water release interval from the pond: 12 hours, 24 hours, 36 hours and 48 hours
- Capacity of the pond: 15 m<sup>3</sup>, 30 m<sup>3</sup>, 45 m<sup>3</sup>, and 60 m<sup>3</sup>.

## 10.2.2 Design Example of Pond Irrigation

The design example of pond as adopted by LILI/HELVETAS is given in Annex 10-1.

## 10.3 Sprinkle Irrigation

### 10.3.1 Sprinkle System Components

The main components of a typical sprinkle irrigation system can be broadly divided into the following:

- Pressurized Water Source
- Pipe Networks (Main Line, Lateral, Riser)
- Sprinkler Heads

The functions and characteristics of each component are briefed hereunder:

**Figure 110-2: Pressurized Water for Sprinkle**



For small and medium size sprinklers the operating head varies between 10 to 30m. Depending on the water source, the various methods are used to obtain the desired pressure of water at the inlet of the unit. The most common methods are:

- Installation of pumping unit
- Gravitational energy (Water source / tank located at higher elevation) and

- Direct connecting from the supply line

### **Pipe Networks**

The pipe network of a sprinkler system consists of the following pipes:

- **Main Line:** conveys water from source and distributes to the sub main. In the configurations without sub main, mainline delivers water directly to the laterals. Mains may be either buried or portable type. The portable types are made of light material such as aluminum, or plastics.
- **Lateral:** delivers water from the mainline to the sprinklers. It can be permanent or portable. Its size is smaller than the mainline. Laterals are laid along the contour of the land.
- **Risers:** The vertical pipe connecting laterals with the sprinkler head is called riser pipe.

### **Sprinklers**

Various types of sprinklers are commercially available. Depending on the mode of operation, sprinklers are can be classified in the following two types.

- Fixed Head Type
- Rotating type

The fixed head sprinklers do not have rotating parts. They are characterized by short range but high intensity. Water is sprayed through the fixed nozzle. Normally they produce fine droplets and therefore best suited for nurseries.

The rotary sprinklers operate due to the impact of the water. The common types of rotary sprinklers are:

- Rotary Impact Sprinkler
- Reaction or Arm sprinkler and
- Butterfly sprinkler

## **10.3.2 Micro Sprinkle in Nepal**

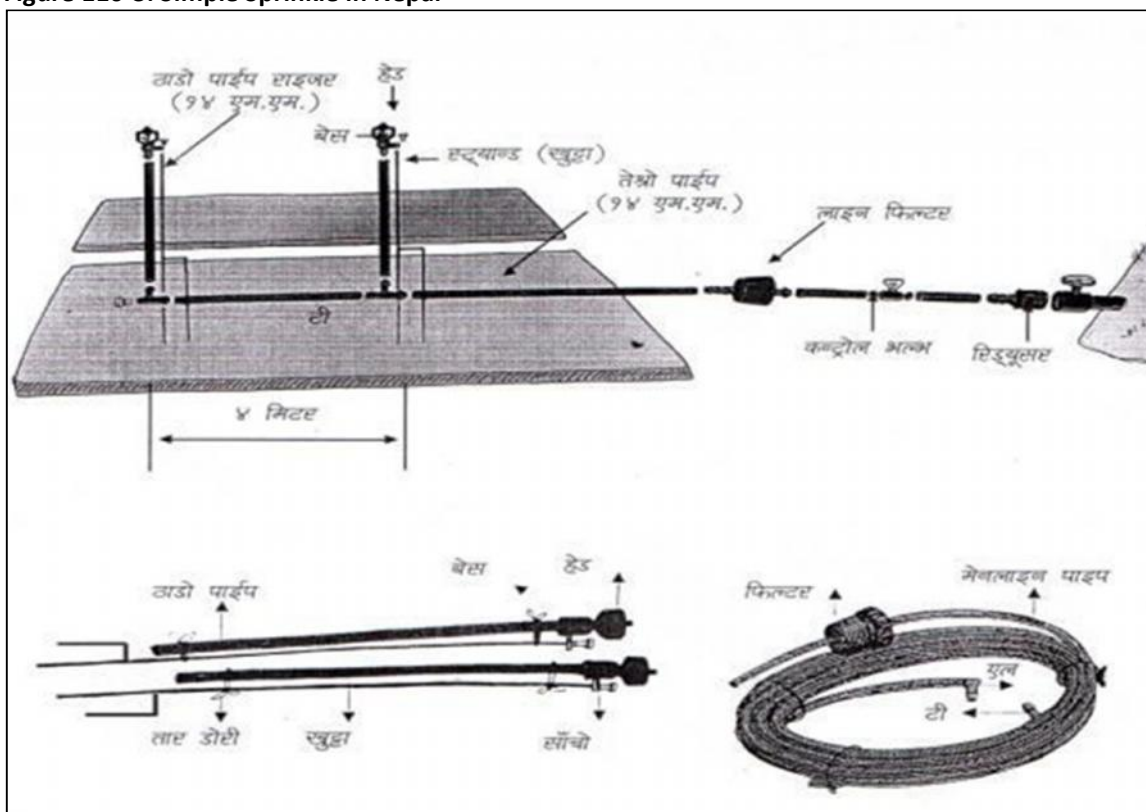
Micro Sprinkler is smaller version of sprinkler, which operates on much less head and flow than normal sprinkler. It can be operated in 10 to 15 m head. The radius of throw of a micro-sprinkler is also relatively small. Because of these technical characteristics, micro-sprinklers are appropriate for irrigating crops in narrow plots and popular in Nepal. This system is movable and easy to change the location to be irrigated.

Because of built-in filter in the system, the sprinkler head does not get clogged. The required pressure head ranges from 10 meters to 15 meters. The required water flow ranges from 0.10 lps to 0.20 lps. The minimum land area is about 2 Anna which comes to about 60 sq. m.

A complete package of Micro-sprinkler system has following parts:

- Main Pipe Line
- Riser Pipe
- Base
- Tee
- Lock
- Stake
- In-line Filter
- MS Head

Figure 110-3: Simple Sprinkle in Nepal



## 10.4 Drip Irrigation

### 10.4.1 Components of Drip System

The typical unit of drip irrigation system consists of mainly following four components:

- Pressurized Water Source,
- Head Unit (Control Head),
- Pipe Networks, and
- Emitters

The functions and characteristics of each component are briefed hereunder.

#### Pressurized Water Source

The operating head of a drip system can vary between 5m to 12 m which is mainly governed by the topography and size of the plot to be irrigated. The desired pressure at the inlet of the drip system is achieved through the following methods:

- Installation of Pumping Unit,
- Direct connecting from the piped supply line, if available pressure is adequate.
- Use of booster pump if the pressure in the supply line is not adequate.



Figure 110-4: Simple Drip Irrigation

In all cases the water may be supplied either through an elevated tank or without it. Pressure regulation is essential in the case of the direct connection systems.

### **Head Unit (Control Head)**

The head unit essentially consists of valves to control discharge and pressure in the entire system. Filters are also integral part of the head unit. Depending on the quality of water one or more types of filters have to be used in the drip system.

### **Pipe Networks**

Pipe network is the water distribution system up to the root zone of the plant. In practice two types of pipe are used for water distribution.

- Pipe without emitters and
- Pipe with emitters

Water from the filters is supplied to the sub-mains by means of main pipe line. They are usually buried below ground, as a permanent setup. Sub-main consists of number of bifurcations to connect laterals pipe or drip pipe. Sub main distributes waters to all laterals fitted to it. Usually the diameter of the sub main ranges between 25 to 50 mm. Laterals are laid along the crop rows on the ground and hold emitters or drippers at a definite spacing. The diameter of pipes used for lateral is usually 9, 12 and 15 mm.

### **Emitters / Drippers**

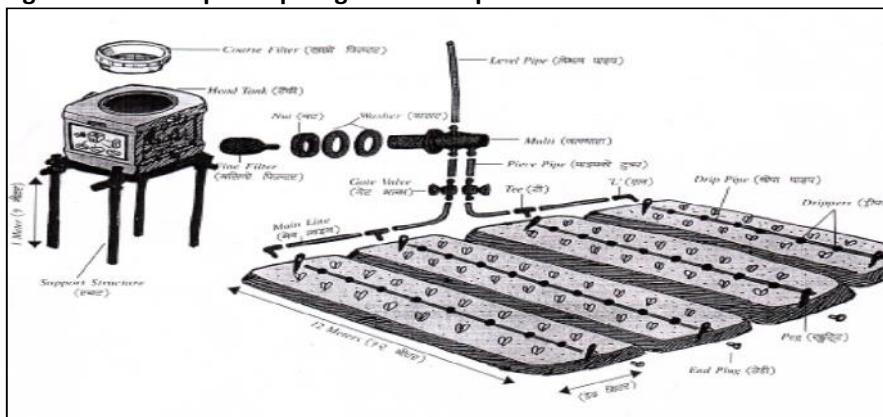
Drippers are small dispensing devices and are affixed to the laterals. The main function of the dripper is to discharge consistent amount of water near the plant in form of drops. Drippers burn off pressure energy to the atmospheric pressure or to create a great head loss. They are so spaced such that the emitting point is close to the plant. Sometimes more than one dripper is provided for one crop – especially for the matured fruit trees. For vegetables with small spacing, drippers may be closely spaced to get a continuous wetting pattern.

## **10.4.2 Simple Drip System in Nepal**

Simple drip system (SDI) is suitable for porous soil where seepage loss is very high and flood irrigation is very inefficient. The land can be plain, rolling or terraced preferably rectangular. It is desirable for the irrigation land to be close to the house for regular monitoring and prevention from damage and theft. The water quality has to be free from appreciable amount of salts, sediments and organic matters. Pre-filtration is required, if the water is sediment laden.

SDI consists of a 50/200-litre tank placed at one meter elevated plat form or pedestal made of bamboo/wooden logs. An outlet pipe connects this tank with a fine filter at the bottom of the pipe to avoid blockage in the drip pipe. Outside the tank there is an outlet set, a level pipe to indicate the level of water and valve to open and close the water flow. The outlet is connected with a 14 mm diameter main line pipe, which is joined to the drip pipe with fittings and an adjustment pipe (Figure 10-5).

**Figure 110-5: Simple Drip Irrigation in Nepal**



## 10.5 Small Scale Lift Irrigation

### 10.5.1 General

When the source of water for irrigation is at the lower elevation than the command area, the water has to be lifted through various means of water lifting devices. Pumping from rivers or streams are examples of lift irrigation. In addition, water for irrigation is also pumped from groundwater sources through shallow or deep tube wells. In this heading small-scale lift irrigation concentrates mainly on the lift from small water sources like streams, springs and ponds. For lifting the water or pumping energy is necessary which is managed by different sources. From the source of energy the power for the lifting devices or pumps can be categorized as:

- Human power such as hand pumps, rower pumps, treadle pumps
- Fossil fuel such as diesel, petrol, gasoline,
- Solar power,
- Wind power,
- Electric power, and
- Water power (hydraulic ram)

The amount of energy required to lift the water depends upon the volume of water to be lifted and required head, which is expressed as:

$$E = \frac{V_w H}{367}$$

Where, E is the energy in kilo watt hour (kWh),  
 $V_w$  is the volume of water in  $m^3$ , and  
 H is the head in meters.

Power is the rate of using energy and is commonly measured in watt (W) or kilowatt (kW) or in horse power (hp). One kilowatt is equivalent to 1.36 horsepower or  $1kW = 1.36$  hp. The power is calculated as:

$$P = \frac{E}{t}$$

Where, E is energy in watt hour, and  
 t is the time in hour.

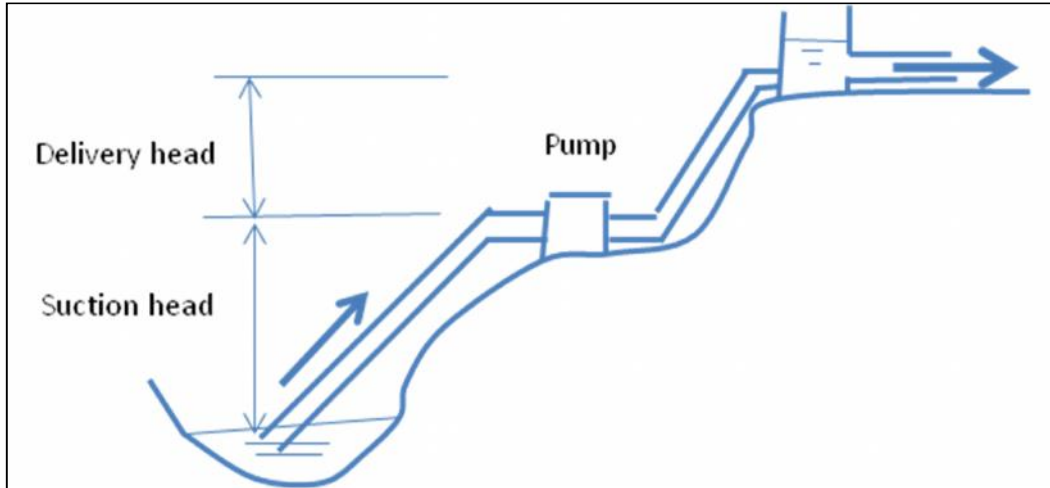
The general equation for the calculation of power is obtained by combining these two equations as:

$$P = 9.81QH$$

Where, Q is the discharge of water flow ( $Q = V_w/t$ ) in liter per second,



**Figure 110-6: Definition Sketch of Small Scale Lift Irrigation**



**Design Example:**

In small irrigation scheme, water demand for irrigation is 600 m<sup>3</sup>/day. Calculate the energy required to lift for 10 m height for pumping of 12 hours per day.

Here;  $V_w = 600 \text{ m}^3$ ,  $h = 10 \text{ m}$ ,

Then the energy required is calculated as:  $E = 600 \cdot 10 / 367 = 16.35 \text{ kWh}$

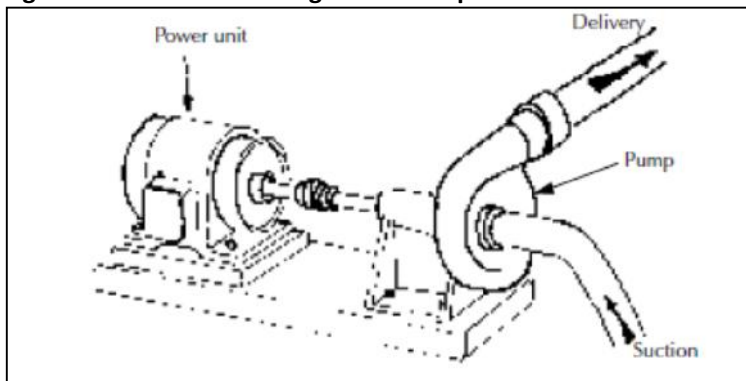
$Q = V_w / t = 600 \cdot 1000 / 3600 \cdot 12 \text{ lit/sec} = 13.89 \text{ lit/sec}$ ,

Then,  $P = 9.81 \cdot 13.89 \cdot 10 / 1000 = 1.36 \text{ kW} = 1.85 \text{ hp}$ .

### 10.5.2 Diesel or petrol engine pumps

Petrol engine pumps are suitable for small lift purpose. These pumps are light in weight and cheaper in cost. Diesel pumps are heavier and costlier in price in comparison to the petrol pumps. Diesel pumps are suitable for long operating hours. Centrifugal pumps are the most commonly used pumps in Nepal. The water is drawn into the pump from the source through a suction pipe and thrown towards outlet through delivery pipe. The schematic diagram of the pump is presented here (Figure 10.7).

**Figure 10-7: Schematic Diagram of Pump**



The pumps characteristics are provided by the manufacturer. The pump selection criteria may be as follows:

- Best possible adequacy between energy power, discharge and head,
- Low cost,

- Long working life,
- High fuel efficiency,
- Low operating cost,
- Easily available spare parts, and
- Portability

Electric motors are suitable where power supply is connected by the national grid or local supply lines. In Nepal different Chinese and Indian manufacture motors and pumps are available in the market to lift the water for small scale irrigation.

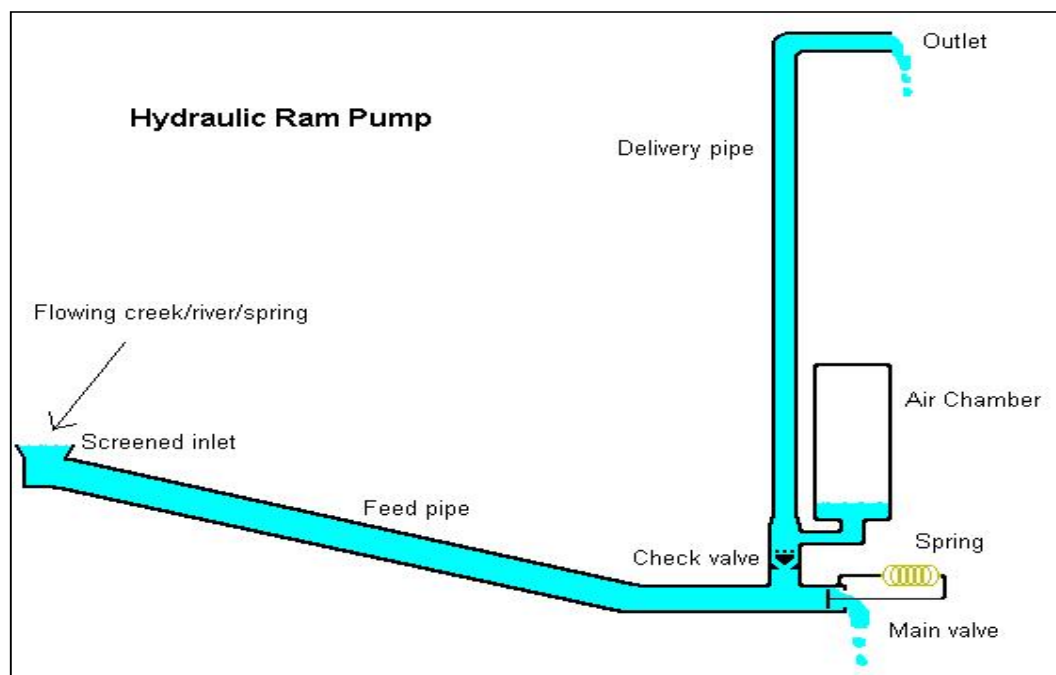
### 10.5.3 Hydraulic Ram

A hydraulic ram or impulse pump is the device that uses the energy of falling water to lift a lesser amount of water to a higher elevation.

Water is run into a feed pipe from a river. When water runs down the pipe it picks up speed and, therefore, momentum. As the flow builds up to a fast rate, it overcomes the mechanical spring pressure on the main valve, causing the valve to close. This stops the flow of water through the feed pipe, but since it has built up momentum, the pressure inside the pump increases. This force of water through the check valve momentarily compresses the air in the air chamber. The air then decompresses, pushing the water through and out of the delivery pipe, while the check valve prevents water from moving backwards through the pump. As the water flows through the delivery pipe and out of the pump, the pressure inside the pump drops, allowing the main valve to open again. This allows the water in the feed pipe to begin flowing again, starting the cycle all over again.

All that is required to make a pump like this function is a minimum of about two feet of drop in the feed pipe, although more drop is desirable as it provides increased flow rates and greater maximum delivery heights.

**Figure 110-8: Definition Sketch of Hydraulic Ram**



### 10.5.4 Treadle Pump

Treadle pump is a human powered water-lifting device from unconfined aquifer of ground water storage. The treadle pump is operated by a stair-step walking motion on two long bamboo poles or treadles, which in turn activate two steel cylinders. The pump uses a bamboo or PVC or HDPE tube well to extract ground water for small-scale irrigation. A bamboo structure (as indicated in the figure) is built over the well with the piston rods attached to pivoted bamboo poles. A treadle pump can be used wherever the depth of static water table is within 6 m. The treadle pump was originally developed in Bangladesh and has been modified based on site conditions.

**Figure 110-9: Treadle Pump**



## 11. Agriculture Benefit Assessment

### 11.1 Introduction

The agriculture is the main stay of Nepal's economy in which more than 70% of the population is dependent. The application of irrigation enhances agricultural production and productivity. The net agricultural benefit with the introduction of the irrigation needs to be assessed for the economic evaluation. The assessment of the agricultural benefit is carried out with the concept of benefit matrix approach.

### 11.2 Benefit Matrix Approach

The benefit matrix is a standardized method of economic analysis based on simplified benefit-cost technique used in irrigation project evaluation. The benefit analysis involves discounting of cash flows of benefits over the life time of the project to assess the economic viability. The benefit matrix is carried out separately for "without project" situation and "with project" situation and net economic returns from each situation are assessed. The net agricultural benefits are the difference of with project benefits and without project benefits.

### 11.3 Components of Benefit Matrix

#### 11.3.1 Command Area

The net area actually cultivated in the "without project" and "with project" situations are given below (PDSP Manual, 1990). This is applicable only for new projects and for rehabilitation project the area will remain same as of without project situation.

	Without Project	With Project
Terai	90%	85%
Hills (<80 slope)	85%	80%
Hills (>80)	80%	75%

#### 11.3.2 Crop Yields

Crop yields are collected from the agricultural survey during the feasibility study of the project. The existing crop yields are used for "without project" situation while for "with project" situation more uniform yields are expected due to application of irrigation. The details of crop yield assumption are presented in tabular form (Table-11.1).

#### 11.3.3 Agriculture Inputs

The main agricultural inputs are seeds, fertilizer, agro-chemicals, labor, and bullock power. The requirement of these inputs for unit land area (ha) needs to be assessed for both "without project" and "with project" situations. For "without project" situation the existing practices of input used is used based on the data and information collected from the survey. For "with project" situation these agricultural inputs are taken from the suggested assumptions as given in Table 11.1.

**Table 11-1: Future “With Project” Crop Input and Output Assumptions**

Region	Crop	Status	Yield (t/ha)	Labour (days/ha)	Bullock Pair (days/ha)	Seed (kg/ha)	N (kg/ha)	P <sub>2</sub> O <sub>5</sub> (kg/ha)	K <sub>2</sub> O (kg/ha)	Agro-chem (NRs/ha)	Misc costs (NRs /ha)
Terai	Paddy	FI	3.00	175	44	30	80	40	0	200	5% of total costs
	Wheat	FI	2.50	110	40	100	90	40	0	150	
	Maize	FI	2.50	123	25	25	60	30	0	100	
	Pulses	PI	0.60	66	19	40	0	0	0	0	
	Oilseeds	PI	0.70	63	24	9	0	0	0	0	
	Millet	NI	1.00	35	0	30	0	0	0	0	
Hills (Tar)	Paddy	FI	3.30	237	48	30	80	40	0	220	
	Wheat	FI	2.80	142	45	100	90	40	0	170	
	Maize	FI	3.00	174	28	25	60	30	0	110	
	Pulses	PI	0.70	89	22	40	0	0	0	0	
	Oilseeds	PI	0.75	95	26	9	0	0	0	0	
	Millet	NI	1.10	49	0	30	0	0	0	0	
Hills (slope)	Paddy	FI	3.30	336	48	30	80	40	0	200	
	Wheat	FI	2.80	196	45	100	90	40	0	170	
	Maize	FI	3.00	245	28	25	60	30	0	110	
	Pulses	PI	0.70	125	22	40	0	0	0	0	
	Oilseeds	PI	0.75	131	26	9	0	0	0	0	
	Millet	NI	1.10	70	0	30	0	0	0	0	

Note: FI-fully irrigated; PI-partially irrigated; and NI-not irrigated

Source: PDSP, Manual, 1990

### 11.3.4 Economic Prices

All prices of agricultural inputs and output need to be converted to economic prices to reflect real value of national economy. There is big variation in the prices of agricultural commodity across the country due to the cost of transportation and hence the prices of each project need to be assessed separately. The prices of crop yields need to be analyzed for the economic farm gate prices. The prices of agricultural inputs are taken from the nearest market prices.

## 11.4 Procedure of Benefit Assessment

### 11.4.1 Total Net Agricultural Returns “Without Project”

- Step 1: Prepare crop input and output assumptions
- Step 2: Calculate farm-gate commodity prices
- Step 3: Prepare “without project” crop budget
- Step 4: Calculate “without project” crop areas in the command area
- Step 5: Calculate total net agricultural returns “without project”

### 11.4.2 Total Net Agricultural Returns “With Project”

- Step 1: Prepare “with project” crop budget
- Step 2: Calculate “with project” crop areas in the command area
- Step 3: Calculate total net agricultural returns “with project”

A sample format of crop budget is presented here (Table11.2).

**Table 11-2: Sample Crop Budget for the Hills “With Project” Situation**

S.N.	Particulars	Units	Without Scheme						Future with Scheme					
			Paddy	Wheat	Maize	Millet	Oil seed	Vegetables	Paddy	Wheat	Maize	Millet	Oil seed	Vegetables
<b>1.</b>	<b>Yields</b>													
	Yield per Crop	Kg / Ropani	99	54	68	53		137	117	67	73	61	21	181
	Rate Per Kg	NRs / Kg	20.5	24.5	15.0	17.0	30.5	28.0	20.5	24.5	15.0	17.0	30.5	28.0
	Value	NRs / Ropani	2'030	1'323	1'020	901	0	3'836	2'399	1'642	1'095	1'037	641	5'068
	By - Products	Quintal / Ropani	2.0	1.0	1.5	1.0	0.0	0.5	2.4	1.2	1.6	1.2	0.5	0.7
	Rate	NRs / Quintal	150	100	50	50	50	50	150	100	50	50	50	50
	Value	NRs / Ropani	300	100	75	50	0	25	355	124	81	58	25	33
	<b>Gross Return (R)</b>	NRs / Ropani	<b>2'330</b>	<b>1'423</b>	<b>1'095</b>	<b>951</b>	<b>0</b>	<b>3'861</b>	<b>2'753</b>	<b>1'766</b>	<b>1'176</b>	<b>1'095</b>	<b>666</b>	<b>5'101</b>
<b>2.</b>	<b>Inputs</b>													
2.1	Seeds	Kg / Ropani	2.5	5.0	2.0	1.0	0.0	7.0	2.5	5.0	2.0	1.0	0.25	7.0
	Rate	NRs / Kg	50	40	40	40	100	75	50	40	40	40	100	75
	Seed value	NRs / Ropani	125	200	80	40	0	525	125	200	80	40	25	525
2.2	Fertilizer	NRs / Ropani	75	50	25	0	0	100	75	50	25	0	25	150
2.2	Pesticides	NRs / Ropani	25	0	0	0	0	50	25	0	0	0	0	50
2.4	Labour	pd / Ropani	5.0	3.0	2.0	2.0	0.0	5.0	6.0	3.6	2.4	2.4	0.0	6.0
	Rate	NRs / pd	200	200	200	200	200	200	200	200	200	200	200	200
	Labor value	NRs / Ropani	1'000	600	400	400	0	1'000	1'200	720	480	480	0	1'200

2.5	Draft Animal	ad / Ropani	2.0	1.0	1.0	0.0	0.00	0.0	2.0	1.0	1.0	0.0	0.25	0.0
	Rate	NRs / ad	400	400	400	400	400	400	400	400	400	400	400	400
	Value animal input	NRs / Ropani	800	400	400	0	0	0	800	400	400	0	100	0
	<b>Total Inputs (I)</b>	NRs / Ropani	<b>2'025</b>	<b>1'250</b>	<b>905</b>	<b>440</b>	<b>0</b>	<b>1'675</b>	<b>2'225</b>	<b>1'370</b>	<b>985</b>	<b>520</b>	<b>150</b>	<b>1'925</b>
<b>3.</b>	<b>Benefits</b>													
3.1	Net Benefit ( <b>NB = R - I</b> )	NRs / Ropani	305	173	190	511	0	2'186	528	396	191	575	516	3'176
3.2	Cultivated Area ( <b>A</b> )	Ropani	842	1'216	1'126	116	0	50	683	1'341	1'416	368	46	622
3.3	Benefit per Crop '000 ( <b>B=AxNB</b> )	NRs	256	210	214	59	0	109	361	530	270	211		1'975
3.4	Command Area (CA)	Ropani				2'074						2'074		
3.5	Cropping Intensity	%				162%						216%		
3.6	Total Benefit ( <b>TB = ∑ B</b> )	NRs				849'273						3'347'812		
3.7	Average Benefit ( <b>AB=TB/CA</b> )	NRs / Ropani				409						1'631		
3.8	Net incremental Benefit ( <b>NIB=Diff. of AB</b> )	NRs / Ropani												<b>1'221</b>
	Total Net Incremental Benefit ( <b>=NIBxCA</b> )	NRs												<b>253'302</b>
		Note: pd = person day				ad = animal day								1 Ropani = 508 m <sup>2</sup>
														1 Quintal = 100 Kg

## **12. Project Cost Estimate**

### **12.1 Introduction**

The cost estimate is defined as the process of assessing actual resources and cost to procure the construction works, services, and goods. The cost estimate also involves the uncertainties and constraints to perform the works. The main objective of preparing cost estimate is to evaluate the possible expenses of the works, services and goods. The cost estimate should be based on the engineering drawings, specification, and actual site conditions. The information necessary to estimate the cost are:

- Location of the site,
- Engineering drawing, specification and job descriptions,
- Proposed date of commencement and completion,
- Proposed methodology of the works,
- Accessibility and availability of materials and plants, and
- Constraints and uncertainties

The project cost estimate comprises mainly three components:

- Unit rates of the items of works;
- Quantities of the works; and
- Cost of the works

The Public Procurement Regulation 2064 provides points to be considered in estimating the cost. This chapter deals with the process and procedures of assessing these three components of the project cost estimate.

### **12.2 Derivation of Unit Rates**

The analysis of the rates of different items of works is calculated on specified format. The district rates are updated in each fiscal year by District Administration Office or Chief District Office (CDO). Rate analysis is carried out in standard unit of the items of works and hence named as unit rate of items. Basically unit rate covers three components:

- Cost of labors,
- Cost of materials, and
- Cost of plants and equipments
- 

The unit rates of the items of the works differ from scheme to scheme and hence need to derive separately for each scheme. The main activities for the derivation of the unit rates are:

- Listing of items of works for a particular scheme;
- Listing of materials to be used for a particular scheme;
- Collection of approved district rates of different labors and materials;
- Collection of market prices of different construction materials;
- Analysis of rates

Example of Rate Analysis is presented in table 12.1



**Table 12-11: Sample Rate Analysis sheet**

A. Earth work in excavation in ordinary soil per m<sup>3</sup>

DoLIDAR Norms No.	Labor					Materials				
	Type	Unit	Qty	Rate	Amount	Type	Unit	Qty	Rate	Amount
2.1 a	Unskill	pd	0.5	300.00	150.00					
	T & P 3 %				4.50					
	Total of Labour				154.50	Total of Materials				0.00

**Rate per m<sup>3</sup> = Rs. 154.50**

B. Random Rubble Stone Masonry work in 1:4 cement mortar per m<sup>3</sup>

DoLIDAR Norms No.	Labor					Materials				
	Type	Unit	Qty	Rate	Amount	Type	Unit	Qty	Rate	Amount
8 c	Skill	pd	1.5	500.00	750.00	Cement	2.32	bag	700.00	1,624.00
	Unskill	pd	3.24	300.00	972.00	Sand	0.47	m <sup>3</sup>	2,500.00	1,175.00
						Stone	1.10	m <sup>3</sup>	1,290.00	1,419.00
	Total of Labour				1,722.00	Total of Materials				4,218.00

**Rate per m<sup>3</sup> = Rs. 5,940.00**

### 12.3 Bill of Quantities and Abstract of Costs

The quantity is calculated according to the exact dimensions of the works fragmented into small geometrical shape and size. Geometrical shapes are rectangle, circle, triangle, parallelogram etc. The quantity is based on the length, width and height or depth of the object to be assessed. Based on the nature of the works the quantity may be in number, area, volume, and length. Some of the items of work are difficult to quantity and hence are expressed in lump sum. For example site preparation, site mobilization etc.

The cost of the works is derived with the multiplication of unit rate and the quantity of each item.

**Table 12.1: Sample format for Bill of Quantities and Abstract of Costs**

<u>Quantity &amp; Cost Estimate Sheet</u>										
Structure: Intake										
S. No.	Particulars	Nos.	Length [m]	Breadth [m]	Height [m]	Quantity	Unit	Rate per unit [Rs.]	Amount [Rs.]	Remarks
<b>1</b>	<b>Earth Work in Excavation in Boulder mixed soil</b>									
i.	Core wall	1	25.00	0.70	0.65	11.38				
ii.	U/S Gabion Protection	1	34.00	1.00	0.50	17.00				
iii.	D/S Gabion Protection	1	34.00	2.00	0.50	34.00				
iv.	Canal Intake Head wall	1	4.00	0.65	1.10	2.86				
vi.	Gabion Protection	1	6.00	1.00	1.00	6.00				
vii.	Intake Floor	1	2.50	1.20	0.40	1.20				
					Total	72.44	m <sup>3</sup>			

## **13. Economic Analysis**

### **13.1 Introduction**

Economic analysis is the process of evaluating best feasible projects among several alternative projects. The main aim of the economic analysis is to assess the economic viability of projects under consideration. The analysis is based on the net incremental benefits arising from the project and the economic cost of the project for its assumed lifetime. To assess the incremental benefit, it is necessary to identify the costs and benefits that will arise with the project and to compare them with the costs and benefits that would have been arisen without the project.

### **13.2 Economic Indicators**

Economic analysis is judged on three economic indicators: Net Present Value (NPV), Economic Internal Rate of Return (ERR), and Benefit-Cost Ratio (BCR). Forthcoming headings briefly describe these economic indicators.

**Net Present Value (NPV)** is the sum of present values of the incremental benefits, discounted at the fixed rate. The project with positive NPV is said to be economically viable and in comparing alternatives, the project with higher NPV would be chosen.

**Economic Internal Rate of Return (EIRR)** is the discount rate which makes the NPV of the incremental benefits equal to zero. It is the discount rate, which ensures that the present value of the project benefits is the same as the present value of the costs. The EIRR of the economic project should be more than the opportunity cost of capital or discount rate (10 %).

**Benefit-Cost Ratio (BCR)** is the present value of the project benefits divided by the present value of costs. If BCR is greater than one, then the project is economically viable for the discount rate chosen.

**Discounting** is the process of comparing present with future amounts of money. Discounting calculates the amount of money required today which, when invested at a rate of interest equivalent to the discount rate, would yield the future amount. Discounting is used to compare the costs and benefits of the project of different times at a single point of time. It is usually at the time of project appraisal. If the capital is Rs 1000 and interest rate is 8% the total capital after one year would be Rs 1080 or in one year Rs 1080 is worth Rs 1000 if discount rate is 8%.

### **13.3 Basic Assumptions**

Basic assumptions for economic analysis are:

- Life of the project- depends upon the nature of structure to be constructed. For small irrigation schemes the life of the project may be 10 years;
- Construction period- the construction period of the project depends upon the size of the works. For small scale irrigation schemes the construction period may be 1-2 years;
- Build up period for full agricultural benefits (1-3 years);
- Opportunity cost of capital in Nepal to be taken as 10 %;
- Standard conversion factor 0.95 for construction costs and 0.90 for operation and maintenance costs.

**Table 13.1: Sample format for Economic analysis**

Year	Construction / O & M cost	Benefit	Cash flow	Discount Factors			Present Value (PV) of Rs '000						
		NRs.	NRs. '000	At 10%	.....%	.....%	Cost			Benefit			
		'000					At 10%	At .... %	At .....	At .....	At .... %	At .... %	
1													
2													
3													
4													
5													
6													
7													
8													
9													
10													
<b>B/C Ratio at 10% =</b>													
<b>EIRR =</b>													

Economic Internal Rate of Return (EIRR)

$$EIRR = HDR + \frac{HDR - LDR}{(BCR \text{ at HDR} - BCR \text{ at LDR})} \times 1 - BCR \text{ at HDR}$$

Where, EIRR is economic internal rate of return,  
HDR is higher discount rate,  
LDR is lower discount rate,  
BCR is benefit cost ratio

**Government of Nepal  
Ministry of Federal Affairs and Local Development  
Department of Local Infrastructure Development and Agricultural Roads  
(Irrigation, River Control & Other Infrastructure Development Section)  
Shreemahal, Pulchouk, Lalitpur,**

**TERMS OF REFERENCE (TOR)**

**FOR**

**Detailed Feasibility Study Report preparation of Small Irrigation Schemes**

..... 2014

## **Background**

Government of Nepal has enacted Local Infrastructure Development Policy (LIDP) 2061 in order to accelerate the pace of rural development and to reduce the rural poverty by improving the access of rural people to goods, service and facilities for the betterment of their life. The policy states that Ministry of Local Development (MoLD) has mandate for implementation of small irrigation projects, whereas it has number of other infrastructure sectors with the responsibility of coordination and facilitation to expedite the process of decentralization. Small irrigation systems are defined as systems having less than 25 hectars of irrigation area in the hills and mountains and less than 200 hectars in the Terai plains. Department of Local Infrastructure Development and Agricultural Roads (DoLIDAR) is the technical department within the Ministry of Local Development and therefore, is responsible for overall management of local infrastructure development on behalf of the Ministry.

Department of Local Infrastructure Development and Agricultural Roads (DoLIDAR) was established for the management of local infrastructures by providing technical backstopping to the local level institutions, especially for the District Development Committees (DDCs). Small irrigation project is now a day is developing by different bodies. Nevertheless, local bodies are also implementing few small irrigation projects every year either solely by themselves or in association with different line/donor agencies, GOs, I/NGOs etc.

DoLIDAR is supporting the local bodies for implementation of small irrigation projects in community level. In this context DoLIDAR intends to hire consultancy services for feasibility study of small irrigation project in ..... District.

## **Objectives of the consulting services**

The main objective of this study is to assess the irrigation potential of the available water resources to meet the irrigation demand of proposed command area. The Specific objectives of this study are outlined below:

- a) To assess water availability in proposed Stream/River for irrigating the command area.
- b) To assess the total command area available for irrigation.
- c) To assess the alignment conditions with cross drainage structure required.
- d) To verify the socioeconomic status of the farmers.
- e) To identify the agricultural activities in the command area.
- f) To assess the technical, economical, environmental and social feasibility of the proposed irrigation system.
- g) Recommendation for further study.

## **Scope of Work**

The scope of work under a detailed feasibility study includes:

- Study and review of reconnaissance or pre-feasibility study of the project, if prepared in earlier study (Desk Study).
- Carry out hydrological, topographical, geological survey and investigations. Collect information on existing infrastructure.
- Conduct socio-economic survey and environmental study of the project and supply area
- Study of multipurpose use of water resource (Irrigation, micro hydro and water supply)
- Measurement of water available in the river.
- Measurement of total command area and canal length.
- Identification of different structure needed for the development of project.
- Calculation of crop water requirement
- Prepare layout, design and dimensioning of the components of the Irrigation System on feasibility study level
- Preparation of Preliminary project cost estimation
- Preparation of the report including the findings of the field study and recommendation with the technical, economical.

## **Methodology**

The entire work of detailed feasibility study report was carried out in three stages:

- Stage first : Field study, Data collection
- Stage second: Reconnaissance design and estimate
- Stage third : Final report preparation

## **Field Study**

The survey team, in close co-operation with Users' Group shall carry out survey of technical works. Users group of scheme will assist the team especially in acquiring the socio-economic information of the area.

- Comprehensive reconnaissance survey around the project area.
- Headwork's study (Availability of water, River width, slope and bed materials)
- Canal alignment and command area survey.
- Assess the cropping pattern (existing & after the project)
- Through analysis of the situation, measurements to be carried out to locate the best suitable headwork, proper canal alignment, cross drainage structures etc.
- Environmental assessment of the scheme

## **Design and Cost Estimate**

After the completion of the fieldwork, the survey team should analyze the data and work out preliminary designs and cost estimate of various components of the projects.

## Report Preparation

Finally based on the design and estimate, report with required drawings shall be prepared.

## Personnel Required

The team of consultants is advised to include following personnel

Personnel:

S.N.	Designation	Input (man-month)	
		Field	Office
1	Team Leader/ Irrigation expert	0.2	0.2
2	Civil Engineer	0.2	0.2
3	Sub engineer/ Surveyor	0.2	

## Qualification and Experience:

Team Leader should have wide experience and expertise in small Irrigation and

- ❖ More than 3 years' experience in Irrigation such as planning, designing, and construction etc with the background of civil engineering.
- ❖ Must have completed Master's Degree in civil engineering.

Civil Engineer should have

- ❖ More than 3 years of experience in irrigation development works.
- ❖ Must be bachelor's degree in Civil Engineering.

Agriculturalist should have

- ❖ More than 3 years' experience in as an Agriculturalist.
- ❖ Must have completed Bachelors' Degree in Agriculture

## Time Frame

The maximum time for the completion of the work will be 3 months and it will be started from the day of agreement between the firm and the Office (DoLIDAR).

## Implementation Arrangement



All the arrangement including logistic support, supporting staffs, movement to field, typing etc to carry out the job should be managed by firm itself with its own convenience.

### **Deliverables**

The consultant needs to submit following reports within 3 months.

#### **Inception report**

Two copies of inception report shall be submitted within fifteen days from contract agreement.

#### **Draft report**

Three copies of draft report shall be submitted within two months from contract agreement.

#### **Final report**

Five copies of final report with soft copy shall be submitted within 3 month from contract agreement. The consultant shall submit the final report incorporating the comments received from the client on the draft report.

### **Mode of payment**

The payment shall be made as mentioned below:

- First Installment (40% of total cost) will be provided after submission and approval of Inception Report.
- Second installment (40% of total cost) will be provided after submission and approval of Draft Final Report.
- Last installment (20% of total cost) will be provided after submission and approval of Final Report.

**Government of Nepal**  
**Ministry of Federal Affairs and Local Development**  
**Department of Local Infrastructure Development and Agricultural Roads**  
**(Irrigation, River Control & Other Infrastructure Development Section)**  
**Shreemahal, Pulchouk, Lalitpur,**

TERMS OF REFERENCE (TOR)

FOR

**Detailed Survey, Design, and Cost Estimate Report preparation of  
Small Irrigation Schemes**

..... 2014

## Background

Government of Nepal has enacted Local Infrastructure Development Policy (LIDP) 2061 in order to accelerate the pace of rural development and to reduce the rural poverty by improving the access of rural people to goods, service and facilities for the betterment of their life. The policy states that Ministry of Federal Affairs and Local Development (MoLD) has mandate for implementation of small irrigation projects, whereas it has number of other infrastructure sectors with the responsibility of coordination and facilitation to expedite the process of decentralization. Department of Local Infrastructure Development and Agricultural Roads (DoLIDAR) is the technical department within the Ministry of Federal Affairs and Local Development and therefore, is responsible for overall management of local infrastructure development on behalf of the Ministry.

Department of Local Infrastructure Development and Agricultural Roads was established for the management of local infrastructures by providing technical backstopping to the local level institutions, especially for the District Development Committees (DDCs). Small irrigation project is now a day is developing by different bodies. Nevertheless, local bodies are also implementing few small irrigation projects every year either solely by themselves or in association with different line/donor agencies, GOs, I/NGOs etc.

DoLIDAR is supporting the local bodies for implementation of small irrigation projects in community level. In this context DoLIDAR intends to hire consultancy services for detailed survey, design and cost estimate report preparation of .....district.

## Objectives of the consulting services

The main objective of this study is to detailed survey, design and cost estimate report preparation of small irrigation project. The Specific objectives of this study are outlined below:

- a. To access water availability in proposed River for irrigating the command area and calculate the total water requirement and water balance of the study area.
- b. To access the total command area available for irrigation.
- c. To carry out the layout, L-section and X-section survey of the project area.
- d. To access the best location for developing the reservoir and related structure.
- e. To verify the socioeconomic status of the farmers.
- f. To carry out the economic analysis of the project with detailed cost estimate, design and drawing.

## Scope of Work

The scope of work under a detailed Design study includes:

- **Feasibility Study**
  - The consultant should carry out the feasibility study of the proposed scheme and if feasible then detailed design study is carried out.
- **Collection of field data/Survey work**
  - Measurement of water available in the river.

- Measurement of total command area and canal length.
- Detailed survey of L-section of the canal alignment and location of the different structures needed for the project.
- Collection of socio economic and agricultural data.
- **Office work**
  - Calculation of the crop water requirement and design discharge of the project.
  - Carry out the dimension, design and cost estimate of water storage system and related structures.
  - Carry out detailed design, drawing and estimate of the project.
  - Carry out the economic analysis of the project.

### 3. Methodology

The consultant shall carry out the study in the following manner.

#### ➤ **Desk Study**

The desk study shall be started immediately after the signing of the agreement and shall consist of but not limited to the following activities:

- Prepare detailed work plan to cover both field and subsequent office work identifying the need to carry out further works based on the information collected as above.

#### ➤ **Field Work**

Field work shall be started immediately after consultation with DoLIDAR and concerned DDC Office. The canal alignment and command area survey should be carried out with the use of GPS for identification study while detailed study shall be carried out with the use of level and Theodolite. The questionnaire should be used to collect and analyze the data. The field work shall consist of but not limited to the following activities:

- Familiarization and Rapid Appraisal of the work
- Fielding of the study team as outline in the work schedule.
- Familiarization of the study team with concerned staff and user community.
- Detail field survey and data collection

#### A. Headwork's Study

- Availability of water.
- River width, slope and bed materials

#### B. Canal Alignment Survey

- Total length of the canal
- Idle length
- Structure needed along the canal alignment
- Chain age of each structure

#### C. Command Area Survey

- Total Command area
- Gross and net command area

D. Socio economic and Agricultural Survey

- Total household and population beneficiaries
- Distribution of population according to caste and ethnicity
- Land tenure holdings, existing cropping pattern and yield, land use, food situation and agricultural input

➤ **Data Presentation and Preparation of Draft final Report**

This part of the study will involve but not limited to the following activities:

For identification Study

Assessment of water available in the proposed project

- The canal alignment condition
- Types of Cross drainage structure needed
- Socio economic status of the farmers
- Status of WUA

For Detailed Study

- Designed discharge
- Size of the reservoir
- Pipe design
- Total Estimate and drawing
- Related structure needed and their detailed drawing and estimate
- Economic analysis of the project
- Socio economic status of the farmers
- Status of WUA

### Personnel Required

The team of consultants is advised to include following personnel

a) Professionals:

Position	Man-Month		Total (M-M)	Remarks
	Office	Field		
Team Leader/Expert in irrigation	0.75	0.25	1.0	Approx. only
Civil Engineer	0.5	0.25	0.75	Approx. only
Agriculturalist		0.25	0.25	Approx. only

## b) Support Staffs

Position	Man-Month		Total (mm)	Remarks
	Office	Field		
Overseer/Surveyors	0.5	0.25	0.75	Approx. only
CAD Operator	0.25		0.25	Approx. only

### ii) Qualification and Experience:

Team Leader/Expert in irrigation should have wide experience and expertise in small Irrigation and

- ❖ Must have completed Master's Degree in civil engineering with 3 years' experience

Civil Engineer should have

2. Must be bachelor's degree in Civil Engineering with 3 years' experience

Agriculturalist should have

- ❖ Must have completed Bachelors' Degree in Agriculture with 3 years' experience

### Time Frame & Cost Estimate

The maximum time for the completion of the work will be 3 months and it will be started from the day of agreement between the firm and the Office (DoLIDAR).

The total estimated cost for detailed Design study of the project is **NRs.** with VAT.

### Implementation Arrangement

All the arrangement including logistic support, supporting staffs, movement to field, typing etc to carry out the job should be managed by firm itself with its own convenience.

### Deliverables

The consultant needs to submit following reports within 3 month.

#### Inception report

Two copies of inception report shall be submitted within 30 days from contract agreement.

#### Draft report

Three copies of draft report shall be submitted within 2.5 month from contract agreement.

**Final report**

Five copies of final report on each of the detailed design of small irrigation system with soft copy shall be submitted within 3 month from contract agreement. The consultant shall submit the final report incorporating the comments received from the client on the draft report.

**Mode of payment**

The payment shall be made as mentioned below:

- First Installment (40% of total cost) will be provided after submission and approval of Inception Report.
- Second installment (40% of total cost) will be provided after submission and approval of Draft Final Report.
- Last installment (20% of total cost) will be provided after submission and approval of Final Report.

## First Socio-Economic and Technical Survey for a Farmer Managed Irrigation System

---

**Name of Scheme:** ..... Reg. Number .....

Name of Surveyor: .....

Date(s) of Survey:.....

Date of Submission: .....

### Definition of Terms

- Canal Irrigation denotes Irrigation system without Pond
- Pond Irrigation denotes Irrigation system with pond and pipe line
- Main Canal/Pipe length: Total pipe or canal length from source to the command area

The Socio-Economic and Technical Survey form should be completely filled in with following details:

- Brief description about project background, location, geography & accessibility to scheme area.
- Need assessment, food sufficiency, existing crops, agriculture service provider & access to markets
- Composition of community and observation of willingness of community participation
- Technical viability, list proposed infrastructures, specific observations like land-slide, rocky area, flooding
- Source capacity in dry season, source protection and Source conflicts
- Role of Organization (local service provider) toward Implementation of Scheme
- Tentative Cost Estimate (on the basis of proposed structure)
- Concrete recommendation either to implement the project or rather not



## 1. Scheme Information:

Name of Scheme: .....

District: ..... VDC: ..... Ward no .....  
 .....Tole:

Type: Canal Irrigation  Pond Irrigation   
 New  Rehabilitation

Name of nearest Road-Head: ..... Distance (hours) (1hr = 3Km)

Name(s) of Source(s): .....

Location: ..... VDC: ..... Ward no

Source: River  Stream  Spring

Command Area (Ropani): ..... Length of Main Canal/Pipeline approximate (m): .....

## 2. Socio-Economic Information

For assessing the socio-economic Situation of the community, fill in the part shown below in the **Detail Baseline Survey Form**

←————— Baseline Field Survey —————→

Name of Beneficiary Households	Caste / Ethnicity				HH Composition			Food Sufficiency		Command Area [Ropani]
	Minorities	Dalit	Janaajati	B/C/T & N	Women	Men	Women headed HH	less than or equal to 6 months (x)	more than 6 months (x)	
DhanKumariThapa				x	4	2	x	x		2
AmaritaThapa				x	6	3	x	x		3
Bir B. Rai			x		3	3			x	6
Bhim B. Rai			x		4	3		x		3
BahadurBitalu		x			3	4		x		1
<b>Totals</b>	Households [HH]				Persons		[HH]	[HH]		Ropani
	<b>27</b>				<b>169</b>		<b>3</b>	<b>21</b>	<b>6</b>	<b>87.0</b>

### 3. Technical Information

#### 3.1 Basic Information of proposed water source

Average measured flow:                      lit/sec	Measured date:
Minimum flow during dry season (according to community people):	

#### 3.2 Current usage of Water sources and Water Rights

Location	Purpose	Quantity (lit/sec)	User	Source registered (Yes/No)
At same location				
Upstream (upto50 m)				
Downstream (upto50 m)				
<u>Water use dispute if any.</u>				

#### 3.3 Alignment of canal

Main canal/pipe length (m):	Active land slide & rocky cliff along alignment	Yes	No
	If yes, length (m) :	Feasible to cross	Yes      No

#### 3.4 Level difference between source and start point of command area (from altimeter)

Altitude at source (m):
Altitude at command area(m):

### 3.5 Proposed structures

Structure	Number	Chainage	Description

### 3.6 Construction materials and Human resources

Description	Available place	Distance
Non-Local Material		
Stone		
Sand		
Aggregate		
Timber		

Name of skilled labour	Address	Area of skills (mason, plumbing, carpentry, gabion weaving)

**Agriculture service providers:**

**3.7 Construction and rehabilitation works in the past**

	Year	External support (yes/ no)	Supported by	Amount funded
First Construction				
Repair & maintenance				

**3.8 Willingness of community contribution**

Cash (Yes/No)	
Labour (Yes/No)	
In kind (Yes/No)	

### **3.9 Social map and layout plan**

*(Ref: Handbook for technicians and facilitators (SEE))*

### **4 Comment by Surveyor:**

**Signature of Surveyor**

## Annex: 4

<b>Earthen Canal Design</b>		03-Sep-12				
Input data:	reach 1	reach 2	reach 3	reach 4	reach 5	
Q_des [m <sup>3</sup> /s]->	0.200	0.030	2.000	0.100		
Bed width depth ratio: b/y r->	1.00	1.00	1.00	1.00		
Bed slope; S_des[1: ....]->	1000	100	350	100		
Bank side slope; m_des ->	1.0	0.0	1.0	1.0		
Manning's n ->	0.025	0.020	0.025	0.025		
<b>Preliminary design</b>						
Flow Depth ; d[m] ->	0.37	0.24	0.88	0.29		
Bed width depth ; b [m]r->	0.37	0.24	0.88	0.29		
Flow velocity; v [m/sec]->	0.43	0.94	1.28	1.13		
Suggested bed slope; S_sugg [1 in ....]->	1000	110	710	160		
<b>Designed standard recommended Value</b>						
Bed width depth ; b [m]r->	0.35	0.30	0.90	0.30		
Flow Depth ; d[m] ->	0.37	0.24	0.88	0.29		
Overall depth; D [m]->	0.50	0.40	1.05	0.45		
Design bed slope; S_des[1 in ...]	1000	110	710	160		
<b>Lined Canal Design</b>		03-Sep-12				
Input data:	reach 1	reach 2	reach 3	reach 4	reach 5	
Q_des [m <sup>3</sup> /s]->	0.200	0.030	2.000	0.100		
Bed width depth ratio: b/y r->	1.00	1.00	1.00	1.00		
Bed slope; S_des[1: ....]->	100	100	350	100		
Bank side slope; m_des ->	1.0	0.0	1.0	1.0		
Manning's n ->	0.020	0.020	0.025	0.025		
<b>Preliminary design</b>						
Flow Depth ; d[m] ->	0.34	0.24	0.88	0.29		
Bed width depth ; b [m]r->	0.34	0.24	0.88	0.29		
Flow velocity; v [m/sec]->	1.59	0.94	1.28	1.13		
Suggested bed slope; S_sugg [1 in ....]->	100	100	350	100		
<b>Designed standard recommended Value</b>						
Bed width depth ; b [m]r->	0.35	0.30	0.90	0.30		
Flow Depth ; d[m] ->	0.34	0.24	0.88	0.29		
Overall depth; D [m]->	0.50	0.40	1.05	0.45		
Design bed slope; S_des[1 in ...]	100	100	350	100		

## Pond Size Calculation

### Design Standard:

- 1 Minimum water requirement at source : 300 liter per Ropani per day
- 2 Average irrigation water demand: 500 liter per Ropani per day
- 3 Peak demand: 3 times of average demand
- 4 Pond capacity: As required to fulfill peak demand or storing 2 days available water (whichever is less)
- 5 Command Area Coverage per Pond: Maximum 40 Ropani and minimum 10 Ropani
- 6 Irrigation interval (water release interval): 48 hr , 36 hr, 24 hr & 12 hr
- 7 Standard Pond Capacity is fixed at 15 m<sup>3</sup>, 30 m<sup>3</sup>, 45 m<sup>3</sup> & 60 m<sup>3</sup>

Project Name:

Mohariya PI, Fulbari

District Name:

Okhaldhunga

### Input Field:

Total command Area (Ropani):

150

Available Discharge at Source

1

(lit/sec):

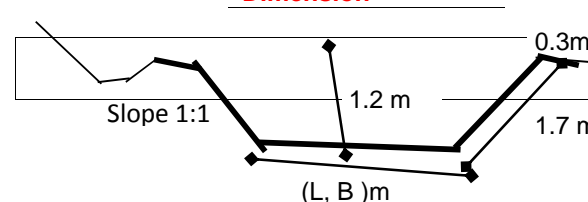
Available Discharge per Ropani per Day:

576.0

Liter

OK!!!

### General Pond Dimension



### Pond Capacity Design Table:

Date of Compilation:

January 14, 2013

Pond No	Command Area [Ropani per Pond]	Available Water [Liters / Day]	Peak Demand [Liters / Day]	Req. Pond Capacity [Liters]	Adopt Pond Capacity [m <sup>3</sup> ]	Time required to fill Pond [hours]	Irrigation Interval [hours]
	C1	C2=C1*D15	C3=C1*500*3	C4=2*C2 or C3 whichever is less	C5	C6=C5/C2	C7
1	38	21888	57000	43776	45	49	48 hr
2	40	23040	60000	46080	45	47	48 hr
3	34	19584	51000	39168	30	37	36 hr
4	38	21888	57000	43776	45	49	48 hr
5		-	-	-	-	-	-
	<b>150</b>	<b>-</b>	<b>-</b>	<b>-</b>	<b>-</b>	<b>-</b>	<b>-</b>

Notes: Cells are locked except yellow shaded input fields

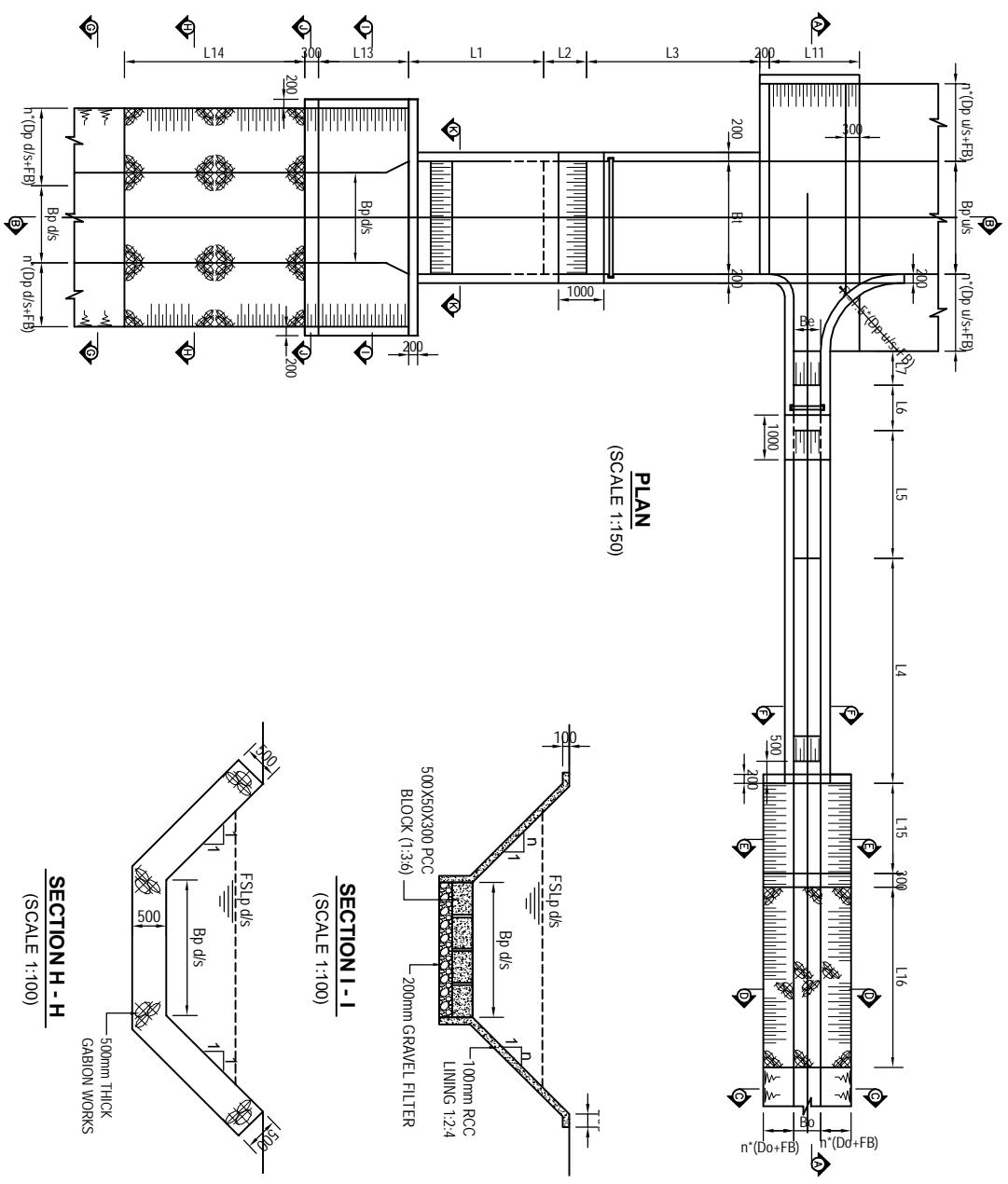
Insert total command area and available discharge to yellow shaded input field

Insert individual pond command areas allocated to each pond on **pond capacity design table** (yellow shaded area)

# Typical Drawings Sample







**PLAN**  
(SCALE 1:150)

**SECTION I - I**  
(SCALE 1:100)

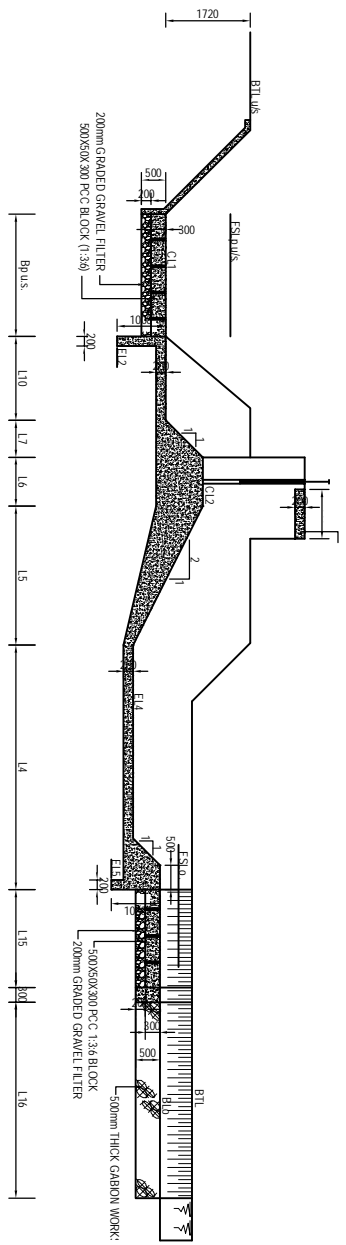
**SECTION H - H**  
(SCALE 1:100)

**SECTION C - C**  
(SCALE 1:100)

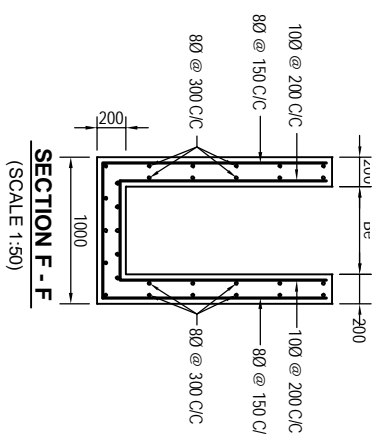
**SECTION D - D**  
(SCALE 1:100)

**SECTION E - E**  
(SCALE 1:100)

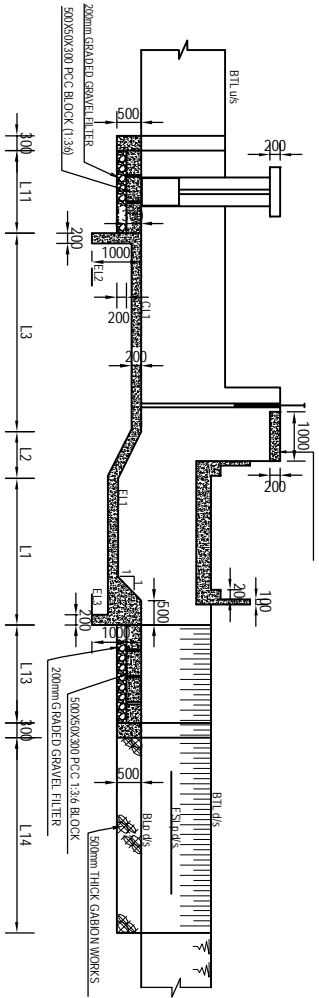
**SECTION G - G**  
(SCALE 1:100)



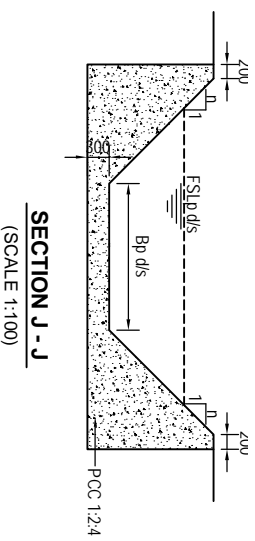
**SECTION A - A**  
 (SCALE 1:150)



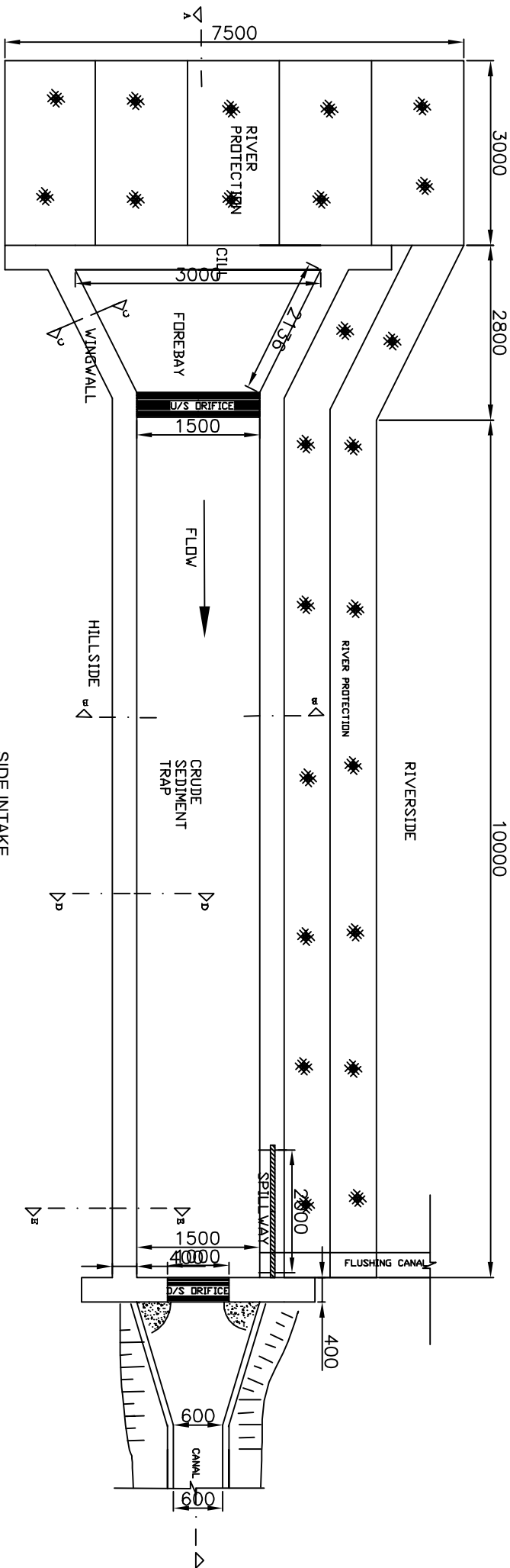
**SECTION F - F**  
 (SCALE 1:50)



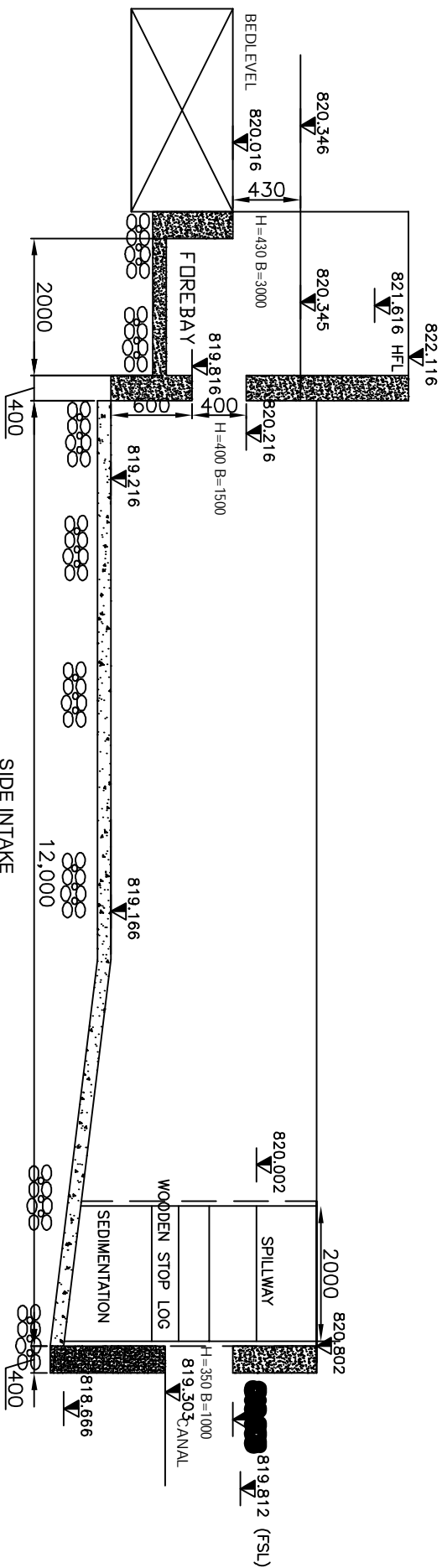
**SECTION B - B**  
 (SCALE 1:150)



**SECTION J - J**  
 (SCALE 1:100)

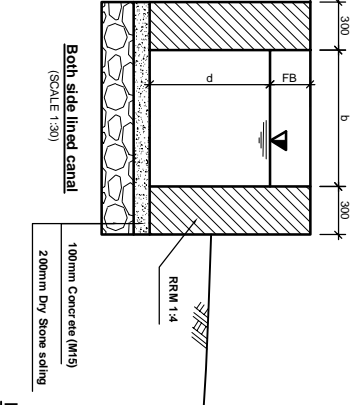
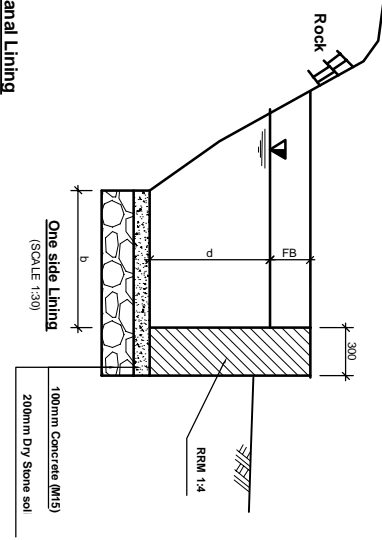
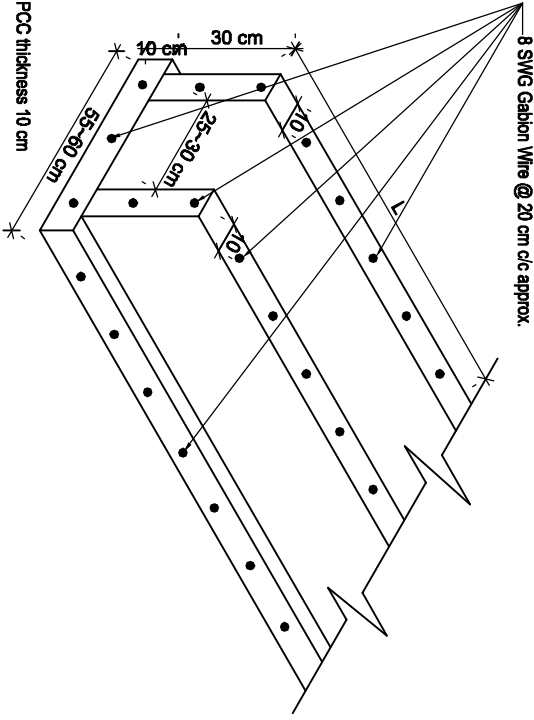


SIDE INTAKE  
PLAN  
SCALE 1:80

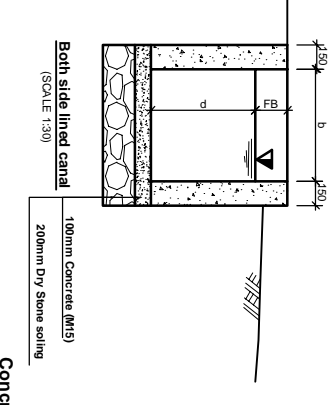
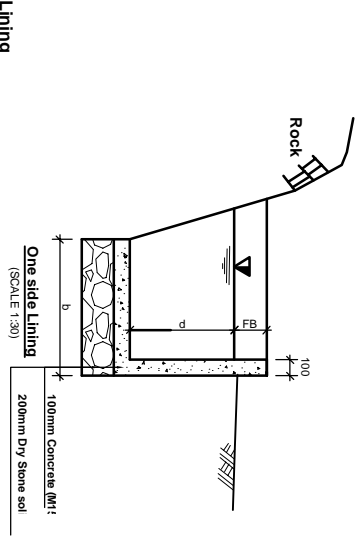


SIDE INTAKE  
SECTION AT A-A  
SCALE B - 1:80, V - 1:85

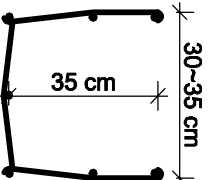
**Concrete Canal for Small Scale Hill Irrigation Schem**  
**Typical Views & Nominal Reinforcement Details**



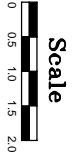
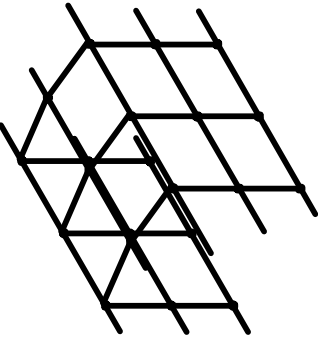
**Masonry Canal Lining**

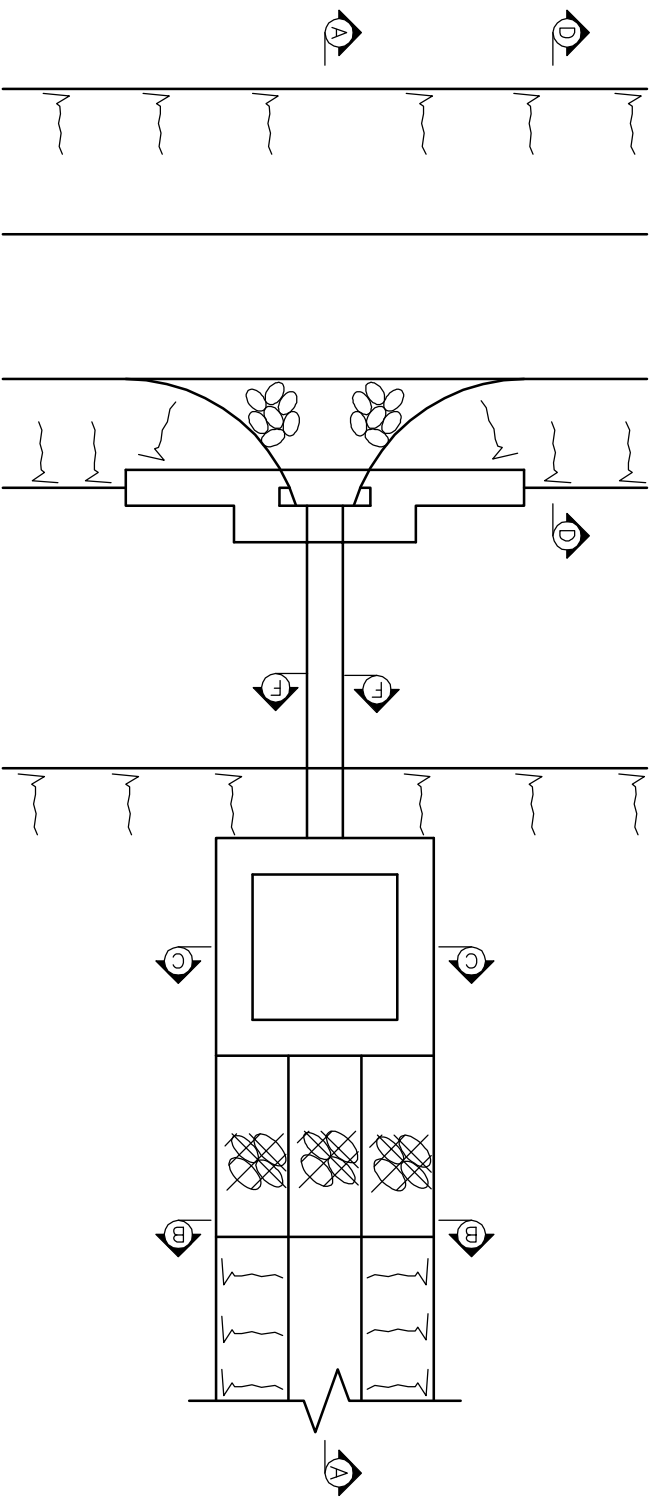


**Concrete Canal Lining**

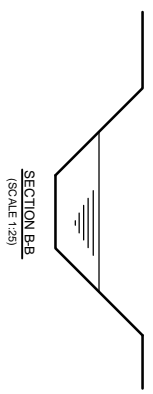


**8 SWG Gabion Wire @ 20 cm c/c**

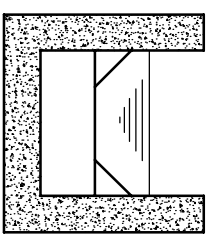




**PLAN**  
(SCALE 1:40)



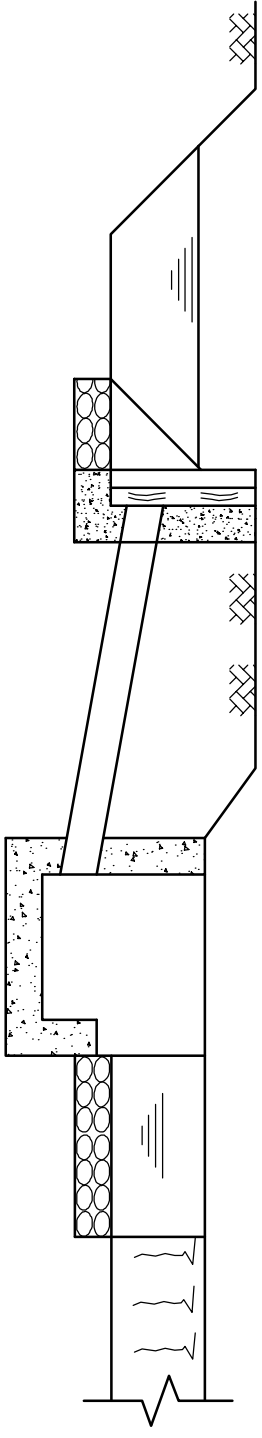
**SECTION B-B**  
(SCALE 1:25)



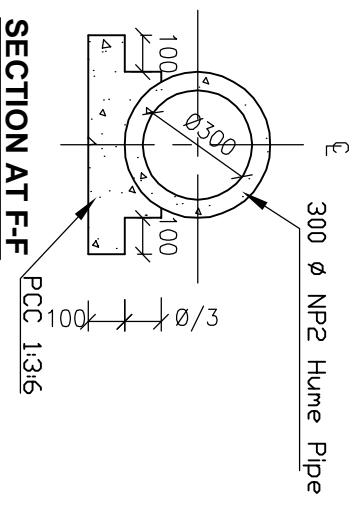
**SECTION C-C**  
(SCALE 1:25)

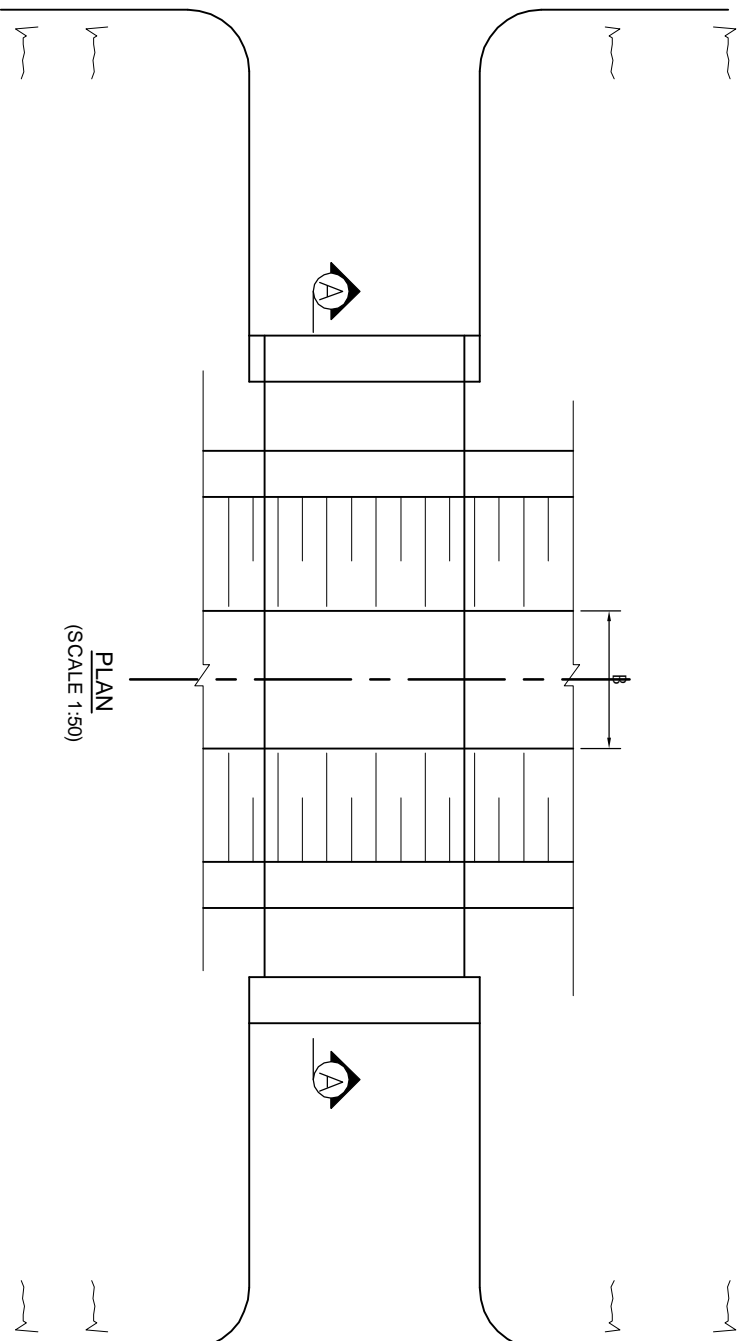


**SECTION D-D**  
(SCALE 1:25)

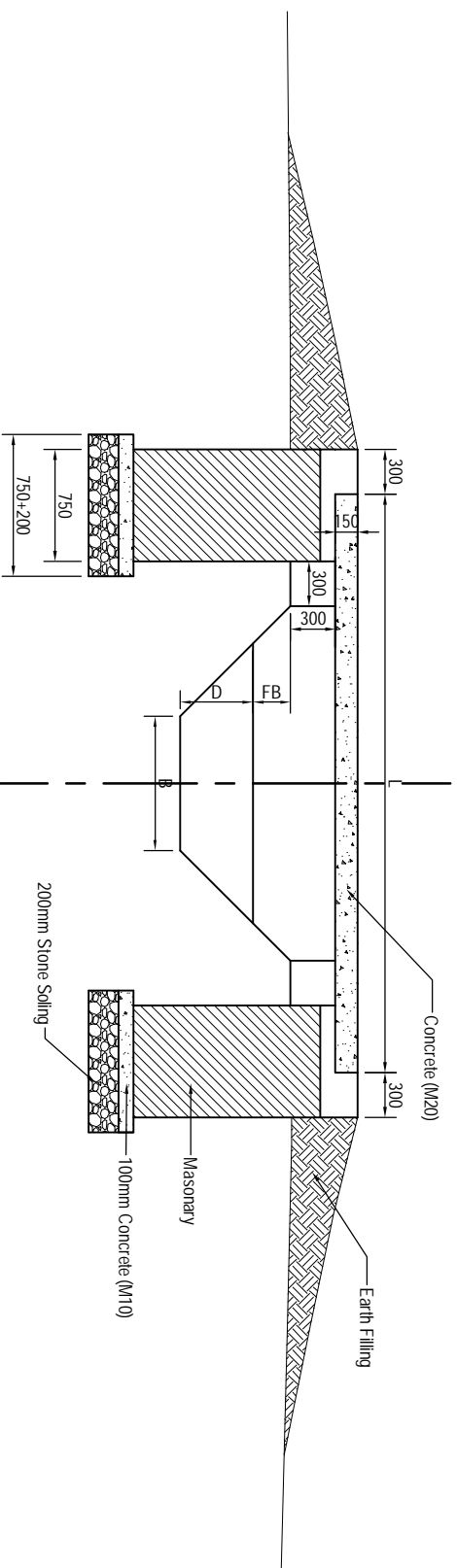


**SECTION A-A**  
(SCALE 1:40)



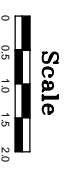


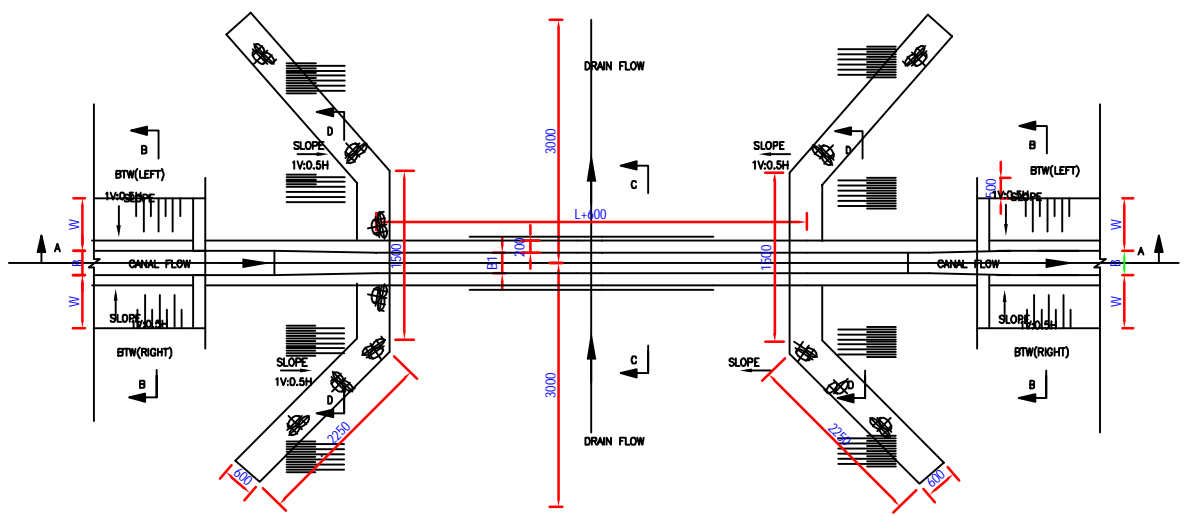
**PLAN**  
(SCALE 1:50)



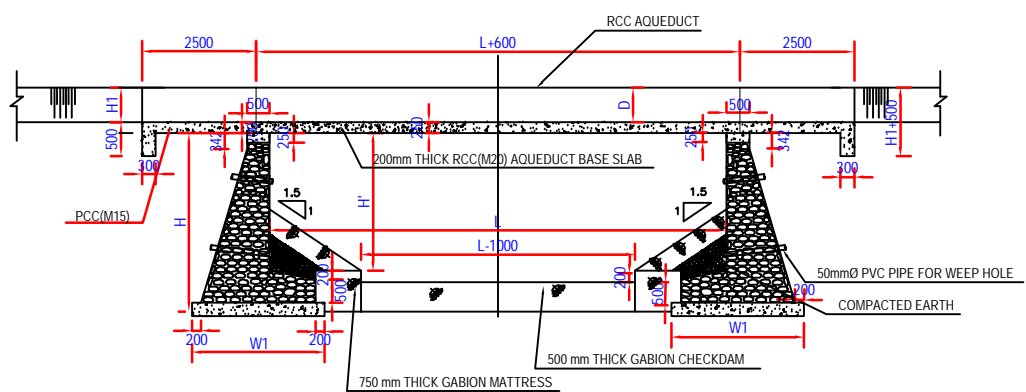
**SECTION AT A-A**  
(SCALE 1:50)

# Typical Foot Bridge

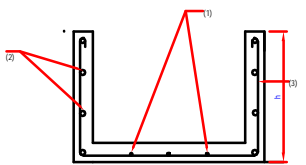




PLAN OF AQUEDUCT

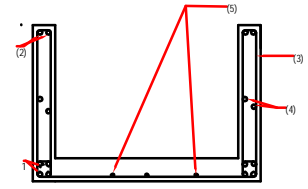


LONGITUDINAL SECTION AT A-A



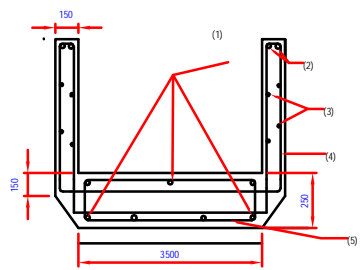
Span 3m to 5m

Span 3m to 5m		
Span	Thickness	Reinforcement Details
Up to 3m	100 mm	(1): 12mm@200mm c/c (2): 8mm@200mm c/c (3): 10mm@200mm c/c
3 to 5m	150 mm	(1): 12mm@150mm/c (2): 8mm@150mm c/c (3): 10mm@150mm c/c



Span 5m to 7m

Span 5m to 7m	
Thickness (t)	Reinforcement Details
150mm	(1): 4 no 12mm (2): 2 no 12mm (3): 10mm@200mm/c (4): 8mm@200mm/c (5): 10mm@150mm c/c

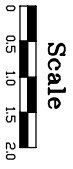
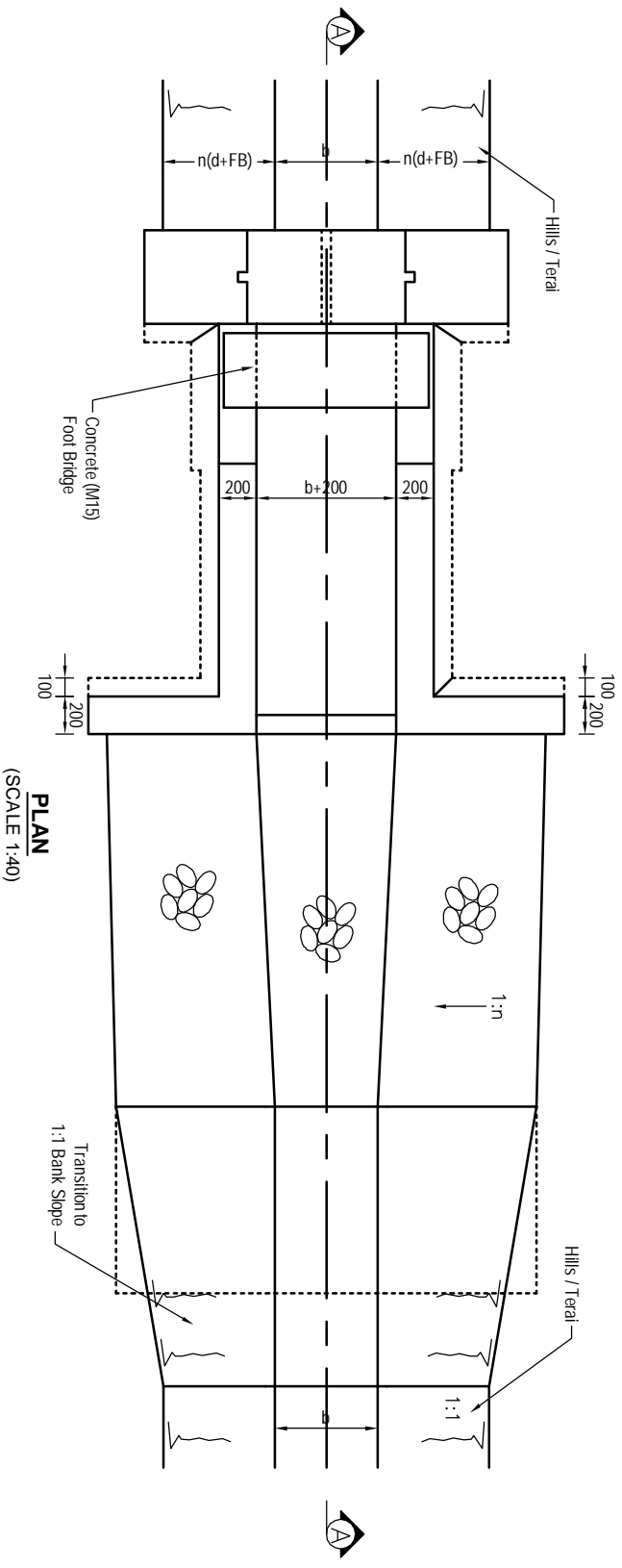
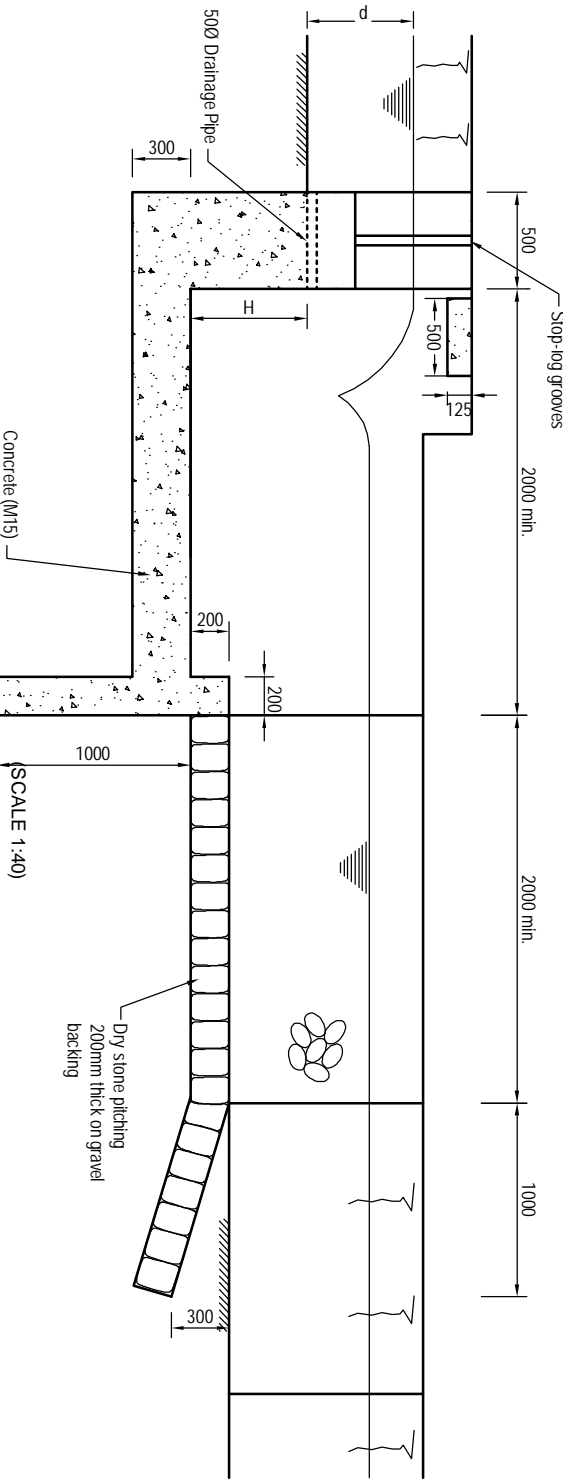


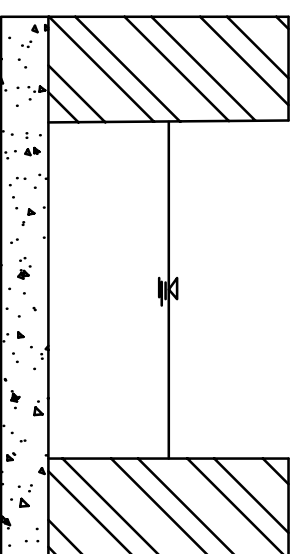
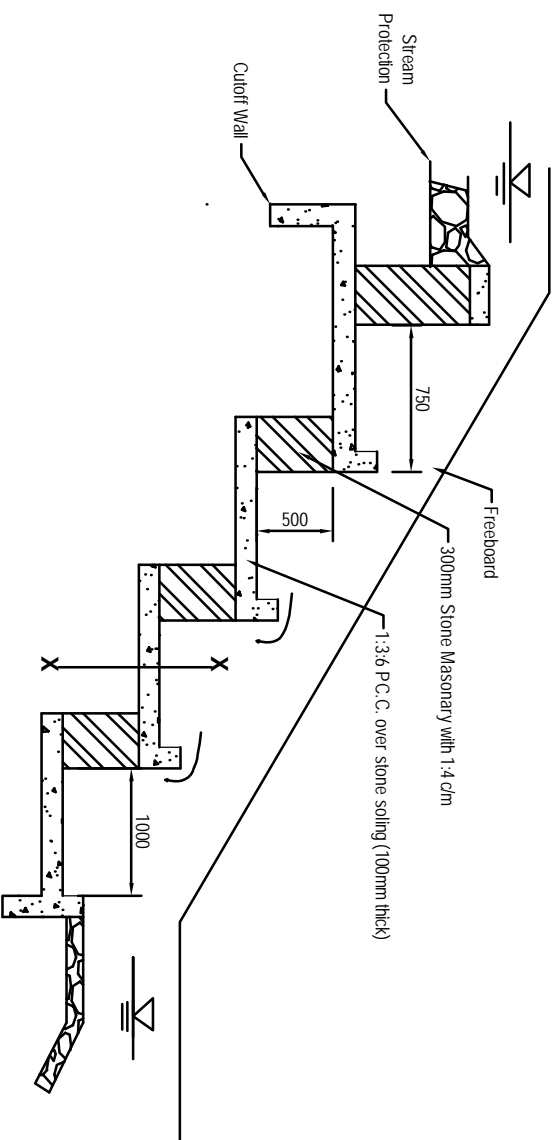
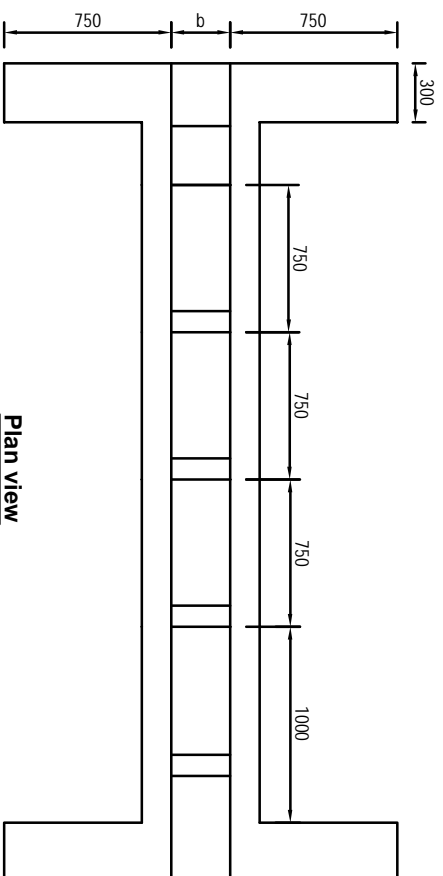
Span 7 to 10m

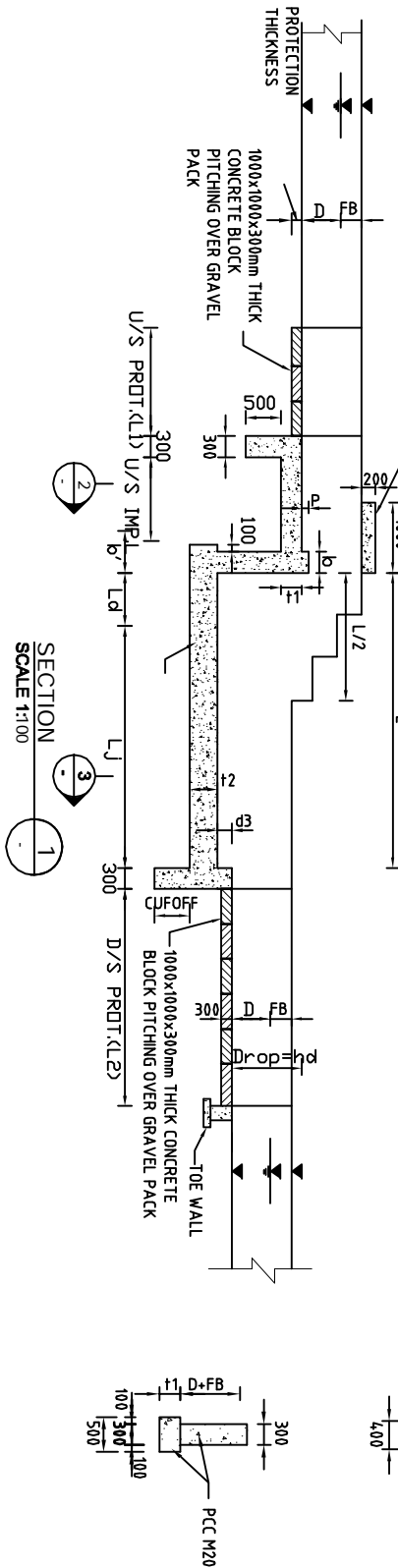
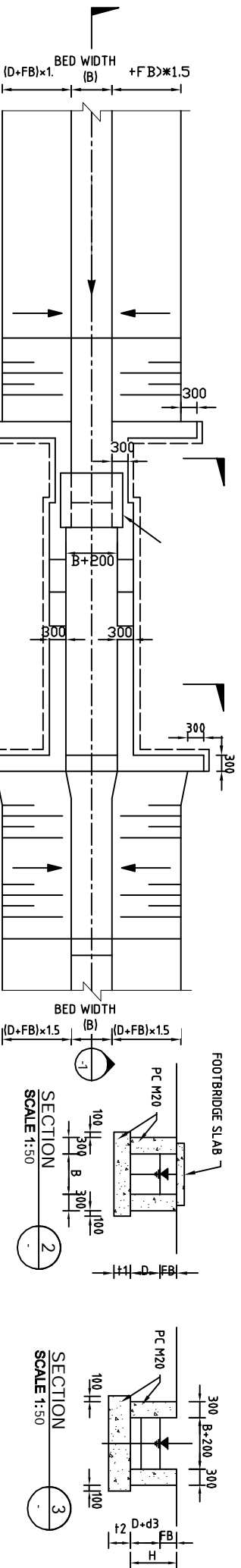
Span 7m to 10m	
Thickness (t)	Reinforcement Details
150mm	(1): 7 (4+3) no16mm (2): 2 no 12mm (3): 10mm@150mm/c (4): 8mm@150mm/c (5): 10mm@150mm c/c



# Typical Drop Structure



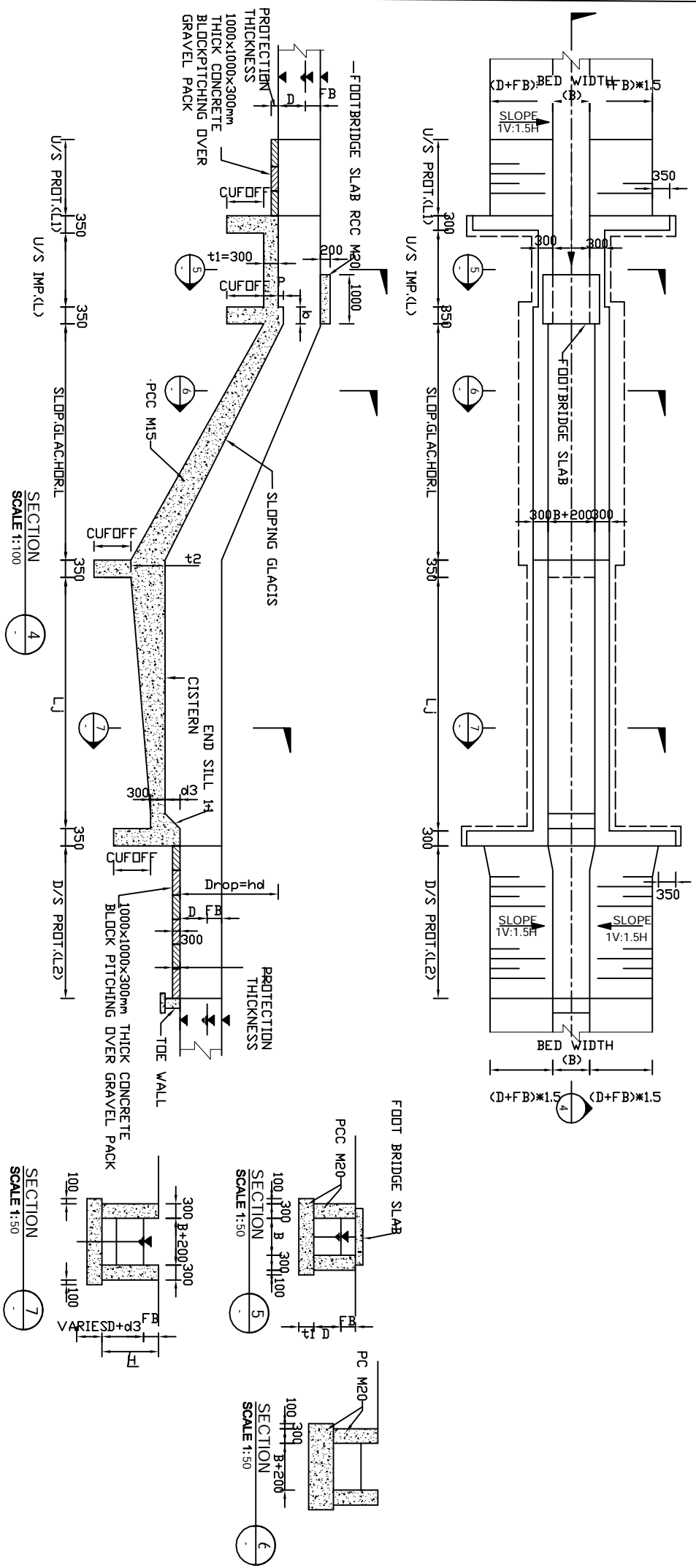


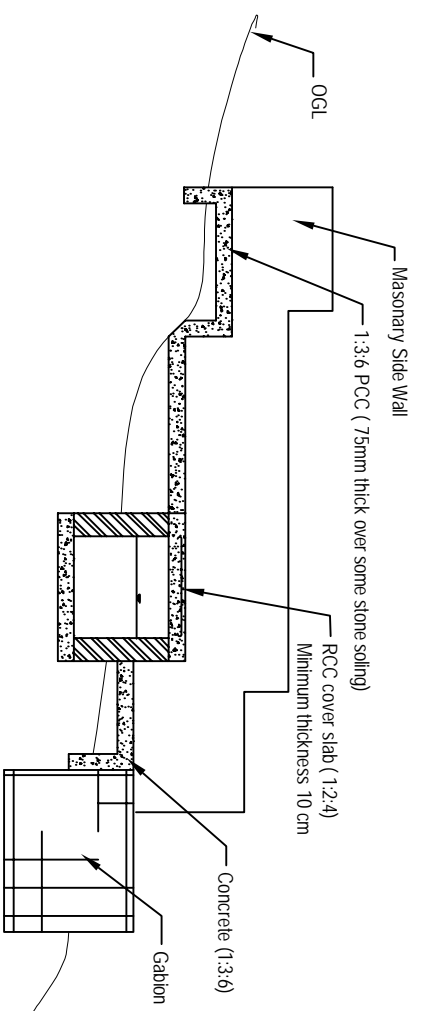
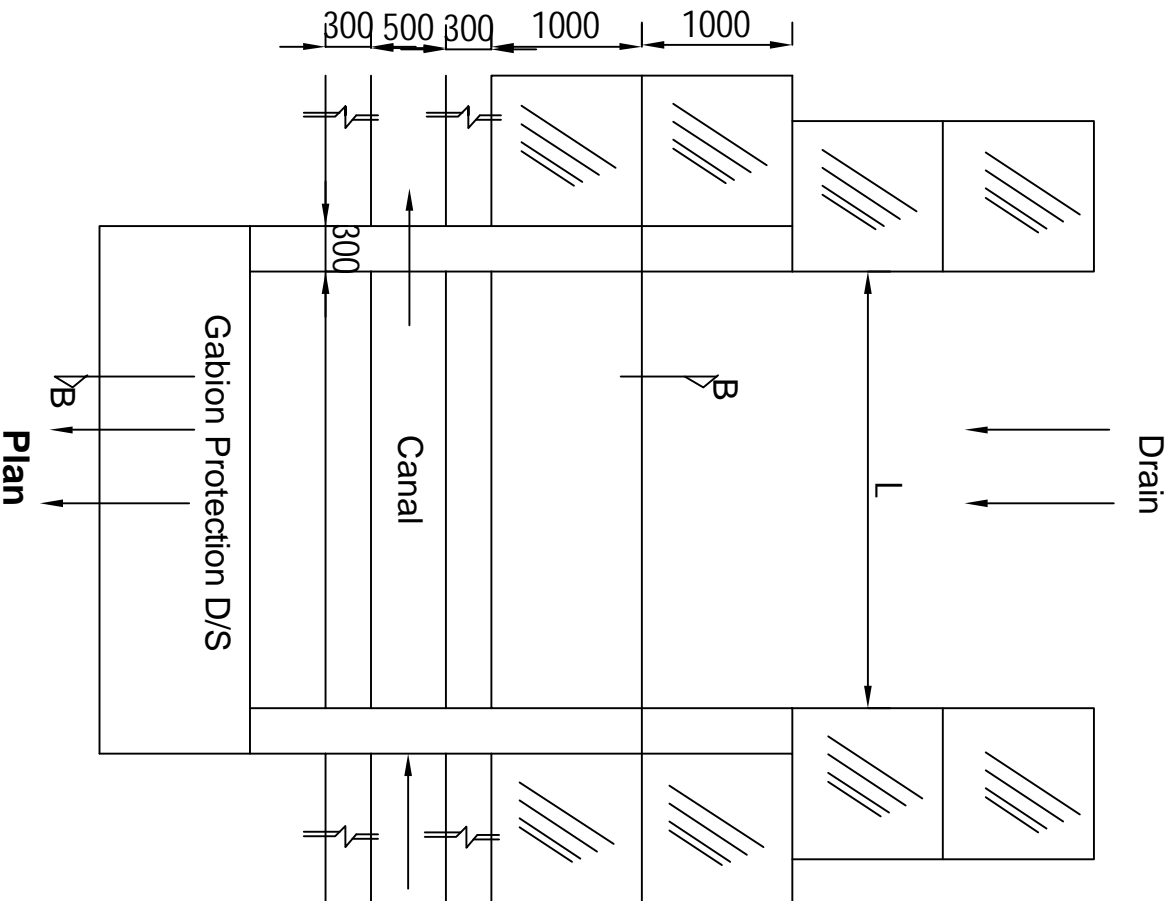


SECTION SCALE 1:100

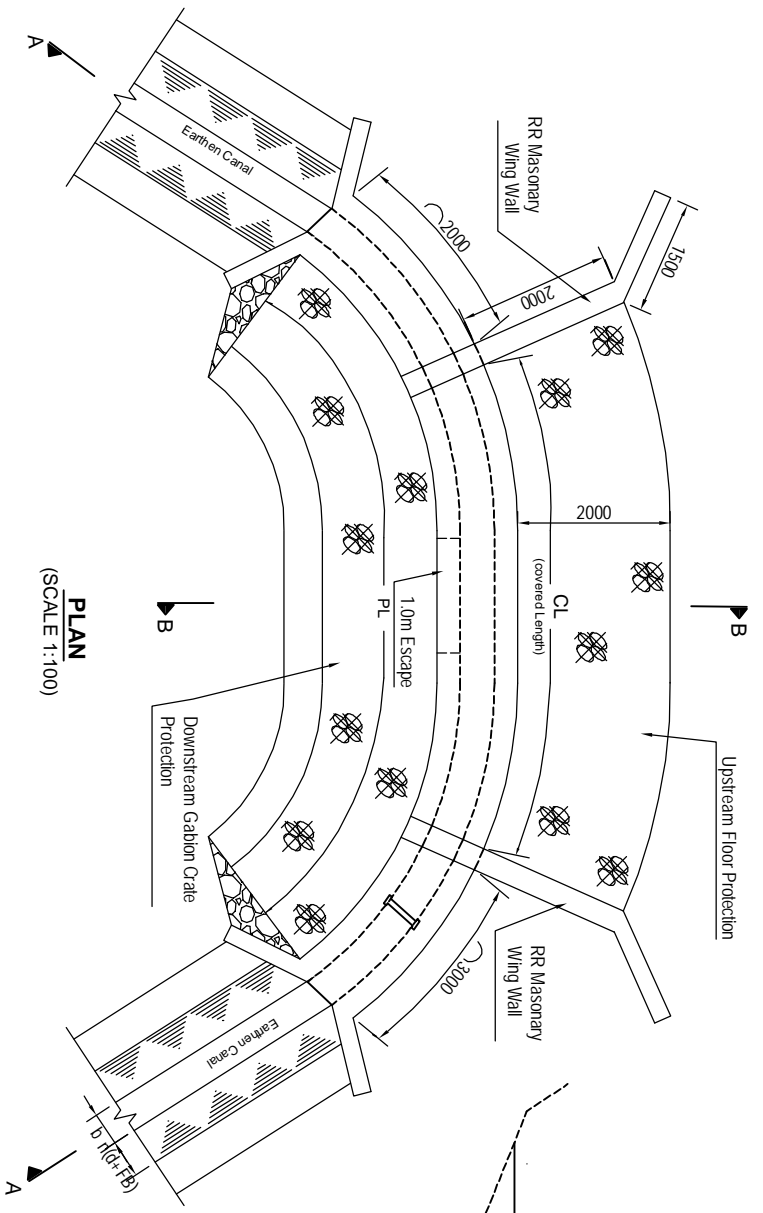
# Typical Vertical Drop

# Typical Chute Drop

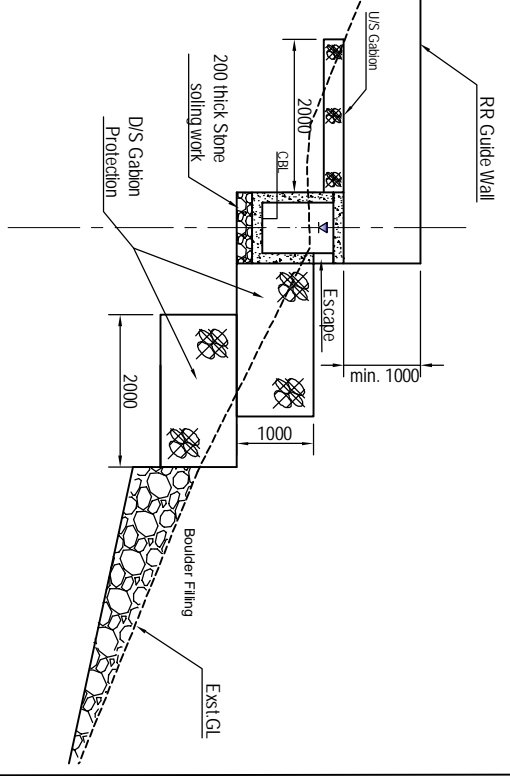




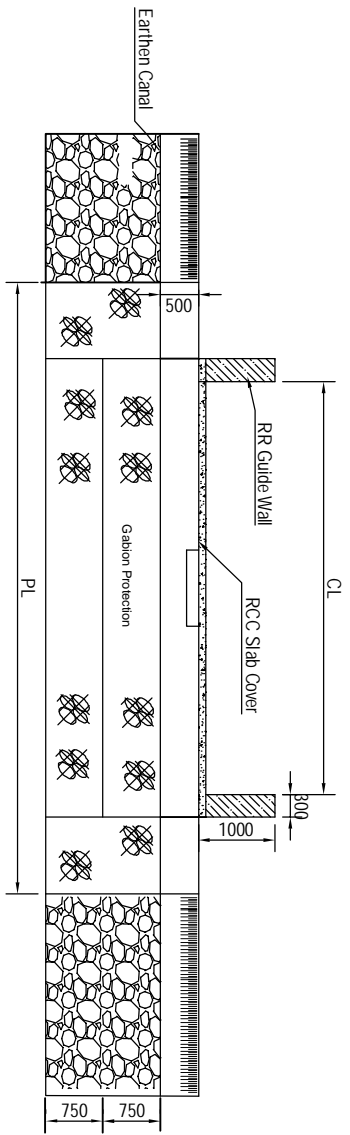
**Section B-B**



**PLAN**  
(SCALE 1:100)

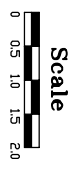


**SECTION AT B-B**  
(SCALE 1:100)



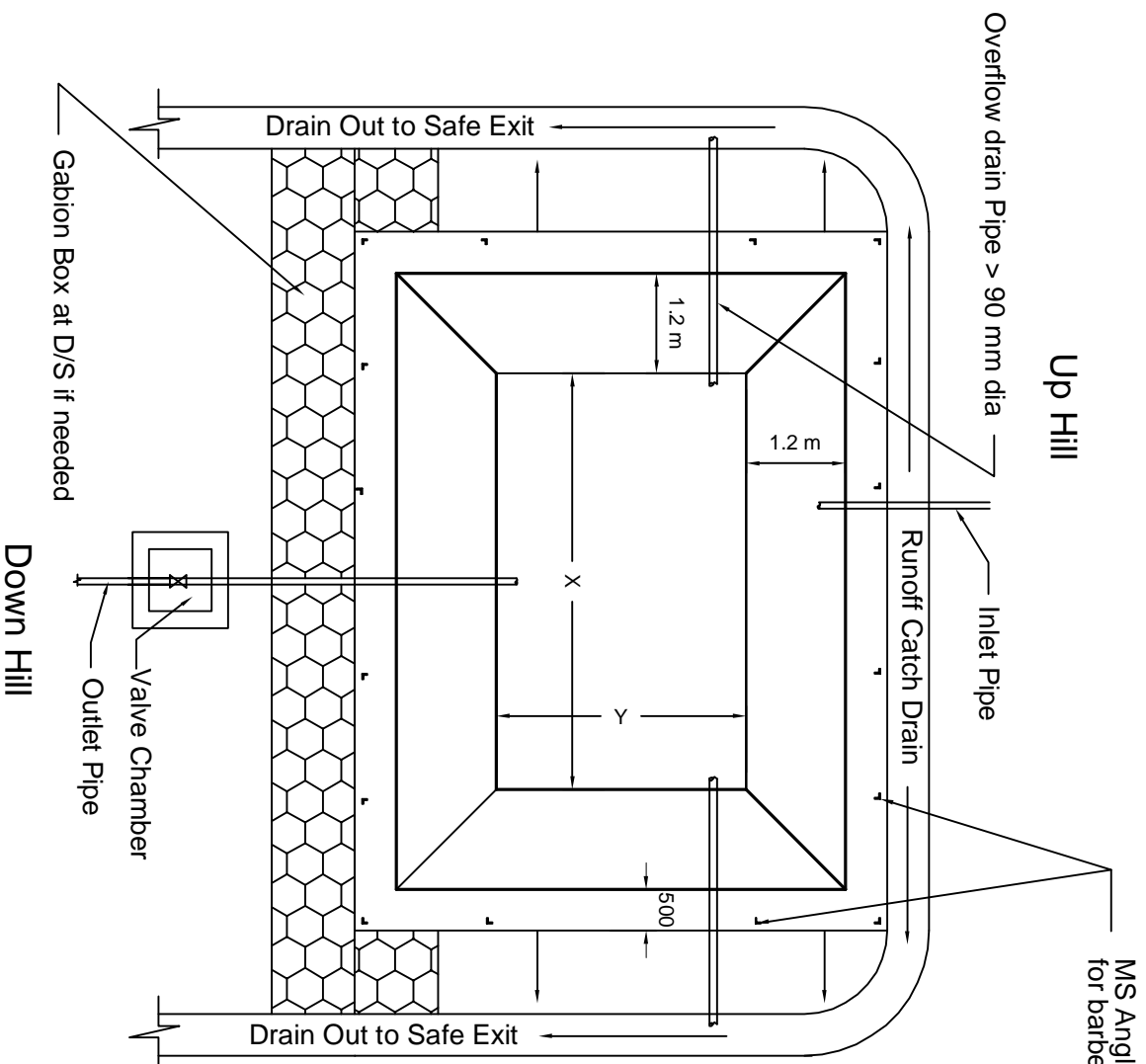
**SECTION AT A-A**  
(SCALE 1:100)

# Typical Super Passage

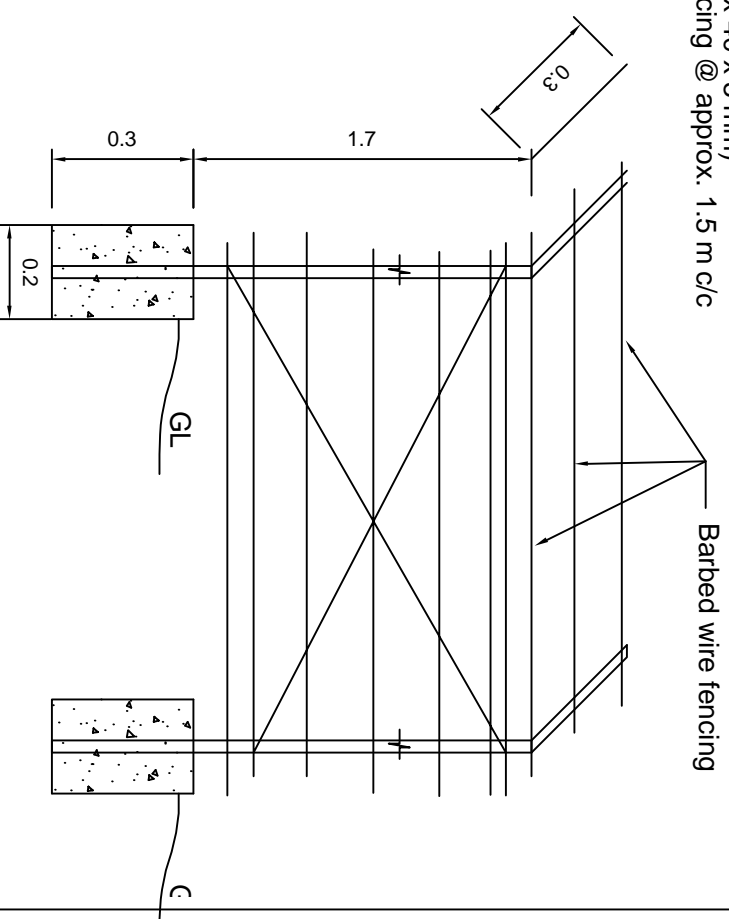


# Pond for Small Scale Hill Irrigation Scheme

## Typical Plan View



MS Angle Pole (40 x 40 x 3 mm)  
for barbed Wire fencing @ approx. 1.5 m c/c



### Safety Measure for Pond Construction

1. Excavate the Pond of designed Size
2. Dress & smooth the Base & Side (no sharp projection remains)
3. Make Bed & Side smooth by spreading Clay Paste
4. Maintain Natural Slope at U/S
5. Built Catch Drain at U/S with two-way slope
6. Provide Overflow Pipes > 90 mm dia
7. Provide Gabion Protection at D/S if necessary
8. Avoid blockage of Overflow Pipe
9. Protection from scouring at exit point of drain
10. Lining with Soil Cement Packed Bags  
(Jute, used cement or other bags)

Government of Nepal  
Ministry of Federal Affairs and Local Development  
Department of Local Development and Agriculture Roads

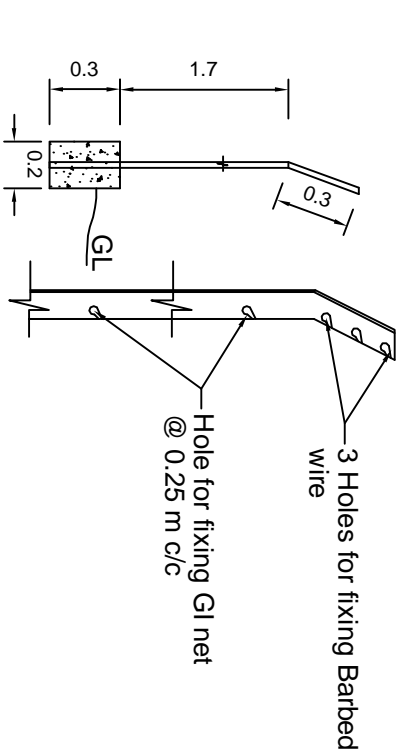
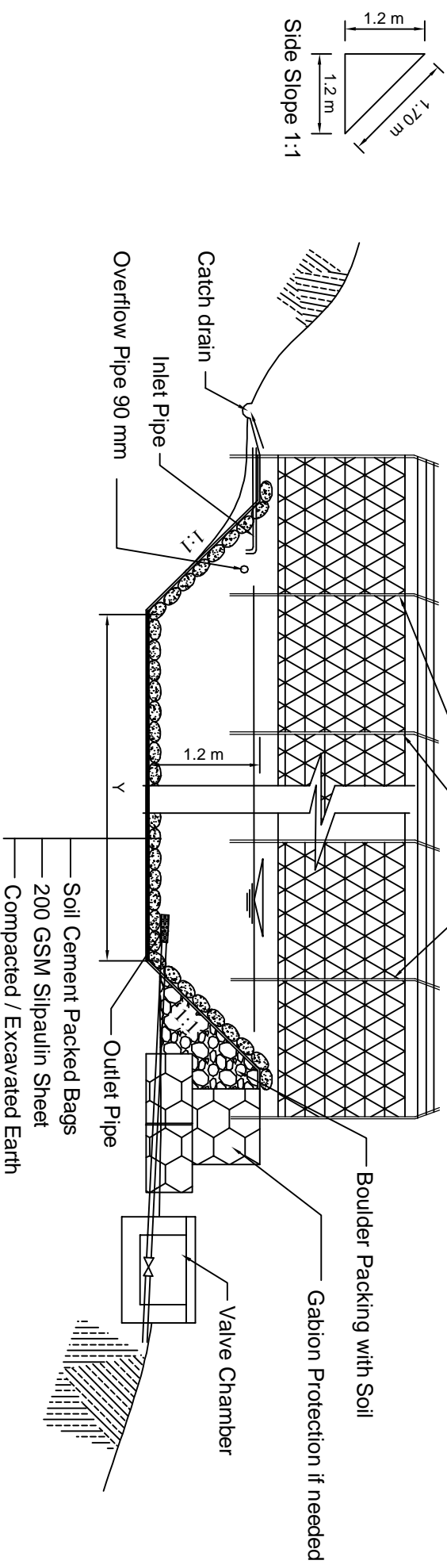
**Plan & Fencing Detail**  
**Plastic Pond**

Scale

# Pond for Small Scale Hill Irrigation Scheme

## Typical Cross - Section

MS Angle Pole 2.3 m high (40 x 40 x 3 mm)  
for fencing @ approx. 1.5 m c/c



Detail of Fencing Pole Fixing

All Dimension are in Meters





Schweizerische Eidgenossenschaft  
Confédération suisse  
Confederazione Svizzera  
Confederaziun svizra

Swiss Agency for Development  
and Cooperation SDC



**HELVETAS** | NEPAL  
Swiss Intercooperation

---

**L I L I is implemented by HELVETAS Swiss Intercooperation Nepal in collaboration with the Government of Nepal and is funded by the Swiss Agency for Development and Cooperation SDC.**